



Non-Motorized Transport in African Cities



Lessons from Experience in Kenya and Tanzania



SSATP Working Paper No.80

Non Motorized Transport in African Cities

Lessons from Experience in Kenya and Tanzania

V. Setty Pendakur

September 2005

The Sub-Saharan Africa Transport Policy Program (SSATP) is a joint initiative of the World Bank and the United Nations Economic for Africa (UNECA) to facilitate policy development and related capacity building in the transport sector of sub-Saharan Africa.

The findings, interpretations, and conclusions expressed here are those of the author and do not necessarily reflect the views of the World Bank, UNECA or any of their affiliated organizations.

More publications on the SSATP website

www.worldbank.org/afr/ssatp

TABLE OF CONTENTS

Acknowledgements	v
Abbreviations.....	vii
Executive Summary	ix
1 Introduction.....	1
2 Urban Mobility in Sub-Saharan Africa	5
3 Urban Mobility in Pilot Project Cities.....	13
4 Institutional Aspects and Project Management	21
5 User Participation and Decision Making Process	31
6 NMT Pilot Projects	45
7 Private Sector Participation	79
8 Examples of Interventions.....	83
9 Lessons from Experience	147
10 References	165
11 Electronic Sources	177

TABLES

Table 2-1. Mobility and modal choice in SSA cities	10
Table 3-1. Urban mobility characteristics in Dar es Salaam and Nairobi	13
Table 3-2. Mobility and modal choice in pilot project cities	14
Table 3-3. Mode choice and trip lengths in Temeke	19
Table 3-4. Mode choice and trip lengths in Morogoro.....	19
Table 6-1. Menu for improving NMT infrastructure.....	49
Table 6-2. Walking speeds in Temeke (1998/99)	50
Table 6-3. Menu for traffic calming.....	53
Table 6-4. Benefit/cost ratio for NMT interventions in Nairobi	58
Table 6-5. Performance indicators for pilot projects in Nairobi	63
Table 6-6. Performance indicators for Eldoret interventions	65

Table 6-7. Performance indicators for traffic calming in Temeke.....	66
Table 6-8. Safety improvements on Temeke Road	69
Table 6-9. Mobility changes in Morogoro 1995 -1998	74
Table 8-1. Modal split on Old DSM Road, Morogoro, 1996*	85
Table 8-2. Break-even pedestrian ADT for walkway investments	95
Table 8-3. Observed vehicle speeds before and after the interventions.....	115
Table 8-4. Modal Split on Temeke Road at the Temeke Hospital*	129
Table 8-5. Bus bay utilization by the minibuses	130
Table 8-6. Bus bay occupancy*	131

FIGURES

Figure 4-1. NMT pilot project management structure	27
Figure 4-2. Alternative NMT pilot project management structure	27
Figure 5-1. User participation structure	32
Figure 8-1. Pedestrian network improvements	87
Figure 8-2. Location of the different improvements	90
Figure 8-3. The new market and the improved walking routes	94
Figure 8-4. Route network: routes and the river	100
Figure 8-5. Design of a raised zebra crossing	106
Figure 8-6. Design of speed bumps on Nile road	110
Figure 8-7. Typical design of pedestrian crossing islands.....	113
Figure 8-8. T-block production design and T-block 'as made"(left)	120
Figure 8-9. Carriageway/shoulder separation with an open drain	120
Figure 8-10. Intersection corner re-alignment	123
Figure 8-11. Medians on Kisumu Road, Eldoret	127
Figure 8-12. Bicycle slips in Morogoro.....	134
Figure 8-13. Road network in Eldoret CBD, with the bicycle track	140
Figure 8-14. Design of the proposed 500 meter length NMT track	141

ACKNOWLEDGEMENTS

This report is based on a review of a number of SSATP Working papers and selected project files of the World Bank. The authors are indebted to Marius de Langen, Theo Rwebangira, Tom Opiyo, Rustica Tembele and collaborators, including municipal staff teams in Nairobi, Eldoret, Dar es Salaam and Morogoro, IHE and Grontmij consulting engineers, for their exhaustive study and pilot project in Kenya and Tanzania, from which this report draws a great deal. Chapters 3 and 5 to 8 as well as many of the photos are derived from their work (de Langen and Tembele, *Productive and Liveable Cities, Guidelines for Pedestrian and Bicycle Traffic in African Cities*). This report also draws extensively from the Assessment of the NMT Program prepared by Scott Wilson for the Sub-Saharan Africa Transport Policy Program (SSATP). We would like to express our thanks to Scott Wilson for this excellent work and many photographs from his other works. Some photos from the Transport Research Laboratory (UK) are gratefully acknowledged.

The authors acknowledge, with thanks, the very constructive comments on the drafts of this report from our colleagues Ben Eijbergen, Ajay Kumar and Richard Scurfield from the World Bank and from Professor Tom Opiyo of the University of Nairobi, Nairobi. Logistical and research support by Carine Megueulle and Fanny Barrett is gratefully acknowledged.

Finally, we wish to acknowledge and thank Rajinder Pendakur for diligent and patient editing, and Eastwood Zhao for research assistance. This report draws from many documents from the World Bank and the outside; however, the errors and omissions, if any, are our own.

ABBREVIATIONS

ADB	African Development Bank
ADT	Average Daily Traffic
AUPT	African Union of Public Transport
CBD	Central Business District
CBD	Central Business District
CEDRES	Centre d'études, de documentation, de recherche économique et sociale, Ouagadougou
CODATU	Coopération pour le développement et l'amélioration des transports urbains et périurbains
CTC	Community Transport Committee
DCC	Dar es Salaam City Council
DSM	Dar es Salaam
ECA	United Nations Economic Commission for Africa
ENTPE	École nationale des travaux publics de l'État
ERB	Economic Research Bureau, University of DSM
EU	European Union
FGD	Focus Group Discussions
GUP	General User Platform
GUP	General User Platform
IHE	Institute for post graduate education and capacity building in Infrastructural, Hydraulic and Environmental engineering (UNESCO-IHE)
ILO	International Labor Organization
INRETS	Institut national pour la recherche en transports et sécurité, Paris, France
IRP	Integrated Road Project, Tanzania
IT	International Team
ITDG	Intermediate Technology Development Group
JICA	Japanese International Cooperation Agency
Ksh	Kenya Shilling
KUTIP	Kenya Urban Transport Infrastructure Project
LET	Laboratoire d'Économie des Transports, Lyon, France
LUP	Local User Platform
LUP	Local User Platform
MT	Motorized Transport
MV	Motor Vehicle
NMT	Non-Motorized Transport
NT	National Team
PPP	Pilot Project Program
PPU	Pilot Project Unit

PUTEA	Étude Mobilité Urbaine et Transport Non Motorisé des Ménages les plus Pauvres (1993-1999), SSATP
RZC	Raised zebra crossing
SITRASS	Solidarité internationale sur les transports et la recherche en Afrique subsaharienne
SOTRA	Société des Transports Abidjanais
SSA	Sub-Saharan Africa
SSATP	Sub-Saharan Africa Transport Policy Program
TOI	Institute of Transport Economics of Norway
TOR	Terms of Reference
TRL	Transport Research Laboratory, UK
Tsh	Tanzania Shilling
TSU	Traffic Safety Unit
UA	User Association
UAR	Union of African Railways
UDD	Urban Development Department, Kenya
UITP	International Union of Public Transport
UMC	Urban Mobility Component
UMU	Urban Mobility Unit
UNTACDA	United Nations Transport and Communications Decade in Africa
UPP	User Participation Platform
USRP	Tanzania Urban Sector Rehabilitation Project
UTC	Urban Transport Component
WB	World Bank
WP	Working Paper

EXECUTIVE SUMMARY

Urban Transport Environment

The vast majority of urban residents in Sub-Saharan Africa (SSA) are from low-income households. The urban poor are dependant on non-motorized transport (NMT) and their urban transport expenditures account for 10 percent (in the smaller cities) to 20 percent of their household incomes. Average urban mobility is low: <2.0 in Dar es Salaam (DSM) and Morogoro, <3.0 in Nairobi, Eldoret and Kinshasa, and <3.5 in Bamako and Dakar¹. Traffic accidents rates are very high, nearly 30-40 times those in the European Union (EU). Pedestrians and public transport passengers are the largest group among the traffic accident fatalities.

Majority of the daily trips are by walk. In Nairobi, Dar es Salaam (DSM) and Eldoret, 47-48 percent of all the daily trips were walking trips and 67 percent in Morogoro. In Dar es Salaam and Morogoro, 40-50 percent of the walking trips were <2 Km and another 40 percent were 2-5 Km in length. Half of these trips took more than 30 minutes. In the large cities, cycling is negligible. However, in some smaller cities, it is popular, reaching around 20 percent of all daily trips in Morogoro. Small-scale private sector is the major supplier of public transport, mainly minibuses. Minibus regulatory system is inadequate and ineffective.

NMT Pilot Projects

Four cities (two major cities and two secondary towns) were chosen for pilot project implementation: Nairobi and Eldoret in Kenya, and Dar es Salaam (Temeke district) and Morogoro in Tanzania. Three distinct types of interventions were planned: building special infrastructure for pedestrians and cyclists, introduction of traffic calming measures and supply side interventions to increase bicycle ownership and use.

NMT infrastructure consisted of dedicated walkways, measures to prevent motor vehicles from driving and parking on road shoulders and walkways, construction of missing links, short cuts, and of bicycle lanes and dedicated cycle tracks. Traffic calming measures included intersection re-design of some intersections to increase their safety and efficiency for NMT, speed humps, raised zebra crossings, pedestrian crossing islands, medians, road narrowing with bicycle slips, and bus bays.

Post project monitoring was done using a set of pre-designed monitoring indicators. In most cases, the NMT program achieved the benefit targets.

¹ Mobility is defined as trips per person per day.

The supply side interventions (limited to the smaller cities) included bicycle sales on credit and on discounts, introduction of women's bicycles, cycling lessons to secondary school students, encouragement of bicycles for hire businesses and organized bicycle parking.

Private Sector Participation

Private sector participation in the NMT projects is detailed in Chapter 7. Historically, the shopkeepers in Nairobi have provided the bollards in front of their shops, to ensure that the walkways are protected from the encroachment by the motor vehicles. This practice is also prevalent in some other SSA cities.

The local community contributed free labor to the construction and repair of the Yombo River bridges in Temeke (DSM). In Eldoret and Dar es Salaam, local community members were involved as labor, underlining the employment generation impact of this type of labor-intensive infrastructure works. Although the local communities surrounding the NMT facilities are in general low-income households, there is a significant potential here for community involvement and partnership. When successful, such partnerships have a sustaining value to the maintenance of the built infrastructure as well as the expansion of NMT facilities. However, the planners and local authorities should be sensitive to the limited capacity of the low-income households to contribute cash.

There is already a very thriving bicycle hire business in Morogoro, with almost 200 micro-enterprises renting nearly 1,500 bicycles. These rented bicycles capture around 30 percent of the daily cycle trips.

The private sector could be a key partner in supply side interventions to increase the bicycle ownership and use. Programs of micro-credit could increase their participation and hence ownership. More importantly, they could enhance the efforts to increase the number of women using bicycles, by providing discounts on women's bicycles. Private sector could also participate actively, through advertising, in the awareness and publicity campaigns as well as cycling education.

Examples of interventions

Sixteen selected examples are detailed in Chapter 8. The details include the background to the interventions, conditions prior to the interventions, objectives of the interventions, what was implemented and the impacts of those interventions. The examples include:

- A. Unobstructed walkway and walkway improvements along a road corridor and narrowing with bicycle slips in Morogoro;

- B. Pedestrian network improvements, raised zebra crossings, pedestrian crossing islands, MT/NMT shoulder separation, intersection corner re-designs and bus bays in Temeke;
- C. Yombo River NMT bridges in Temeke and Sosiani River bridge in Eldoret;
- D. Speed humps in Nairobi;
- E. Intersection corner re-design, medians, a bicycle track and a mixed NMT track in Eldoret, and
- F. An example from Morogoro, to illustrate how we can learn from errors.

Lessons from Experience

The “Lessons from Experience” together with the rationale behind these lessons, are detailed in Chapter 9. The lessons are listed below.

A. NMT in SSA cities

- i. Improvements to NMT environment, mainly used by the poor, could be a way to increase urban productivity and thus reduce poverty. If the primary objective is to provide a safe and efficient travel environment, then a very high priority must be given to large-scale traffic calming measures throughout road network, and provision of safe NMT road space along the major arterial road network. This has to be a long-term commitment as it requires a quantum leap in urban traffic culture. Municipal and national government staff training is an essential ingredient of this change in culture, as are improved traffic law enforcement, road user education and traffic management.
- ii. For the next decade (to 2015), provision of proper pedestrian infrastructure must have the highest priority in urban transport investments to achieve major urban productivity gains and contribute directly to poverty alleviation.
- iii. The smaller cities offer a major potential to increase cycling as a daily travel mode. However, unless the overall traffic situation is safer, cycling does not appear to have a significant potential for increase in large cities.
- iv. The large cities suffer from a severe backlog in pedestrian infrastructure, and offer a high potential to improve walking infrastructure facilities.

B. Institutional aspects and project management

- i. Only a part of the NMT program, proposed by the international consultants, was implemented in Nairobi. Decision-makers and the professional staff in Nairobi considered these proposals too disruptive to motor vehicle traffic flow. In addition, the efforts to establish linkage to the Kenya Urban Transport Infra-

structure Project (KUTIP) were not successful partly because of timing and partly because of the clients' unwillingness. However, linkages to other projects (World Bank funded Tanzania Integrated Road Project-IRP, Tanzania Urban Sector rehabilitation Project-USRP and the JICA funded road project in DSM) were quite successful and several NMT components were incorporated.

- ii. Building successful links to other major urban transport projects is necessary and important. The pre-requisite to successful linkages is the ability to convince the lending agencies and donor agencies of the need and importance of cooperation. At the operational level, it is important that the Task Team Leaders (both the World Bank and the client) of the linked projects are sensitive to and interested in building NMT infrastructure facilities.
- iii. Management structure adopted for the pilot projects was essentially a "top-down" structure. While this achieved the objective of meeting the deadlines, it quite possibly undermined the progress towards the other core objectives of the project namely, institutional development and capacity building.
- iv. To achieve success, local government and consultants (both international and national) must be transparent from the beginning regarding the available project funds, their allocation and use. "No false promises or expectations" are the cornerstone of successful user participation.
- v. Institutional structures should enable proper empowerment of the local authorities as it creates a sense of ownership and perhaps continuity.
- vi. The management structure adopted for NMT project implementation should put the users and the local authorities at the center of the process of implementation. This empowerment is a pre-requisite to continuity.
- vii. Training is an important strategic instrument not only for disseminating new knowledge but also for capacity building and increasing the awareness of the needs of NMT users. Training and workshops conducted by the international consultants and the national teams were very successful in building a knowledge base and creating awareness regarding the importance of NMT programs.
- viii. To ensure long-term capacity building and continuity of commitment to improving NMT infrastructure, local authorities should take charge of the implementation process, the users should be at the center of that process and training and awareness programs should be integral to project implementation.
- ix. Pilot projects have generated a significant amount of new knowledge and experience. It is important to disseminate this knowledge in an organized, effective and economic way to enable SSA urban transport professionals to acquire new knowledge and implement NMT programs in their own areas.

C. User participation

- i. Effective user participation is central to community empowerment and continuity of policies supportive of NMT programs. If participation is not properly structured, it can be costly, cumbersome and frustrating to all parties. It is important to strive for a balance between complete citizen controls of the projects on the one hand and total professional control on the other.
- ii. Effective participation requires professional staff that recognizes its importance and believes it can make a positive contribution to project interventions at all levels and at all stages.
- iii. Large-scale awareness campaigns are costly and have limited impacts without a proper follow up. The best approach is targeted awareness campaigns combined with NMT interventions.

D. Impact of physical interventions

- i. The NMT infrastructure investments are highly cost-effective.
- ii. Traffic calming measures were successful in reducing dangerously high motor vehicle speeds considerably, while not reducing average route speed, because of lower section and intersection delays because of a smoother traffic flow. Aggregate effects of traffic calming were quite positive. Traffic accidents decreased noticeably, especially fatalities. Unfortunately, some pedestrians continued to use shortcuts while crossing the streets, even if it meant coming into conflict with traffic.
- iii. Reduction in speed can result in substantial increases in traffic safety; this can be achieved by simple traffic calming measures such as raised zebra crossing and or speed humps.
- iv. Traffic safety must be assured over the long-term to retain any gains in cycling arising from improvements in the NMT environment.
- v. Recognizing the fact that many local authorities in SSA have very meager resources for construction and maintenance, the construction of NMT infrastructure inventions should make allowance for low cost equipment and adopt labor-intensive methods.
- vi. The pilot project experience demonstrates that the design of some NMT infrastructure, while appearing to be straightforward on the surface, can be quite complex. This is due to the need to understand the behavior patterns of NMT and motor vehicle users, and to be able to design the NMT infrastructure for lack of maintenance capability at the local government levels and in general, very low levels of traffic law enforcement.

- vii. Dedicated bicycle tracks, where there are no dedicated pedestrian walkways, will not be successful. In reality, the bicycle tracks will literally be taken over by the pedestrians.
- viii. When cycling infrastructure is combined with appropriate pedestrian infrastructure, the NMT improvements are likely to be successful.
- ix. The NMT missing links and shortcuts are very cost effective and used intensively by low-income households.

E. Design issues

- i. NMT infrastructure design should be such that they require very little maintenance and construction materials are sturdy with long life.
- ii. The design of NMT facilities, which involve pipes, fittings and other metal fixtures, should be such that they are vandal-proof.

F. Hawkers and vendors

- i. If unrestrained, hawkers and vendors will encroach on to the newly built walkways and cycle tracks, which result ultimately in reduced capacity and wasted NMT investment.
- ii. It is possible to control and regulate vendors and hawkers, thus protecting the NMT investments.
- iii. It is possible to incorporate proper space for vendors and hawkers in the design of bus bays, thus increasing public amenity as well as creating a revenue source for the local governments.

G. Sustainability issues

- i. Decision makers and some professionals in SSA do not consider NMT interventions a priority. Therefore, the World Bank and donor agencies might need more strings attached to the innovative NMT programs, to enable a change in the mindset of these decision makers and professionals.
- ii. Maintenance and renewal was a major problem. Damaged and or stolen infrastructure had not been replaced. Traffic law enforcement was inadequate, if any and minibuses continued to encroach on walkways and pedestrian islands, and sometimes stopped for passengers at the raised zebra crossings.
- iii. It is possible to design and implement appropriate NMT infrastructure facilities in SSA cities. However, these investments are not sustainable unless there is adequate maintenance and proper enforcement regarding encroachment by street traders and minibus operators.

- iv. Over the long term, as experience and knowledge change the attitudes of the decision-makers and professionals, NMT facilities will become an integral part of urban transport planning in SSA. However, a long-term commitment from the World Bank and other donor agencies is required in order to sustain the efforts in the planning and implementation.
- v. Traffic safety, both real and perceived, is a pre-requisite to increase cycling in SSA cities, in addition to introducing avenues for the low-income households to own a bicycle.

H. Missing links and shortcuts

- i. In making strategic NMT investments for missing links and NMT only bridges, it is important to assure that the community and the private sector are partners in development, and at the same time, recognize the limited capacity of the low-income households to contribute cash rather than labor.
- ii. Two missing links and short cuts: NMT only bridges on Yombo River in Temeke and on Sosiani River in Eldoret were highly successful. They provided efficient and convenient shortcuts, saving substantial walking cycling time for NMT users. The initial gains in cycling observed in Eldoret because of traffic calming at one important accident black spot disappeared after a while. Cycling is not likely to increase extensively merely because of cycle tracks but gains are more likely only when cycling is perceived to be a safe mode of travel.

I. Supply side interventions

- i. The program to sell bicycles on credit (through a savings and credit cooperative society) and at a discounted price for women as well as cycling lessons in secondary schools were highly successful. Efforts to organize bicycle in parking lots and on hire-purchase plans were not successful.
- ii. Because the traditional financial institutions are not forthcoming in this field, the World Bank should consider a program of micro-loans, through employer/employee institutions and other mechanisms, for larger scale programs of making bicycles purchase more accessible.
- iii. In most SSA cities, there is a large unfilled potential for cycling by women. Its promotion and teaching to secondary school students should be an integral part of the World Bank's urban transport projects in SSA.
- iv. As a positive step towards urban cycling in SSA, urban transport projects should include mechanisms to establish "bicycle for hire" micro-enterprises.

J. Institutional issues for future projects

- i. Is it feasible to expect technical staff within local authorities in SSA to deal with the complexities of designing effective NMT infrastructure, even if guidelines are available in the form of a manual? Alternatively, will it be necessary to provide permanent technical assistance either from the private sector or from the central government?
- ii. Are transportation planners and engineers, who are used to traditional approaches, willing to give equal priority to NMT and motorized transport?
- iii. What is an appropriate level of user participation, which is sustainable within the resource constraints experienced by most local authorities? How to attain a balance between the need to involve users and the need for local authorities to exercise proper control of activities and the outcomes?
- iv. Are local authorities willing to promote and facilitate direct user financing of NMT infrastructure in exchange for greater accountability? Are users willing to take up this challenge?
- v. In order to answer these questions, it will be most likely necessary for the World Bank to work with a much wider number of local authorities in SSA.

K. Future research

Specific areas of research which could benefit NMT planners are:

- i. Identification of appropriate and sustainable construction materials in countries, which are easily available and require very low maintenance;
- ii. Construction materials for NMT infrastructure which are highly visible to drivers and require low maintenance;
- iii. Speed reduction and appropriate crossing point design on arterial roads;
- iv. Appropriate traffic calming measures for different classes of roads;
- v. Criteria for locating the raised zebra crossings since they were not all well used by pedestrians;
- vi. Optimal spacing of speed humps and optimal location criteria for raised zebra crossings;
- vii. Design options and criteria, for speed humps and raised zebra crossings, which can eliminate the formation of potholes behind and in front of raised zebra crossings; and
- viii. Design standards for appropriate infrastructure for NMT.

L. Future SSATP activities

The assessment of the NMT pilot interventions has raised a number of key issues that could be addressed in future interventions². Activities that could be undertaken to consolidate and further develop the achievements of the NMT pilot projects include:

- i. A survey of standard NMT infrastructure design details already used by local authorities in SSA. Assess the potential usefulness of consolidating these designs and the experiences of the pilot projects into a design manual for NMT infrastructure. Analyze the suitability of these designs in relation to the lessons learned on the pilot projects.
- ii. A manual of standard designs that could be used widely in the region. Establish the appropriate level of sophistication for such a manual.
- iii. Encouraging a higher profile for NMT issues by establishing a Challenge Fund. This fund would be available for committed local authorities in SSA to develop their own capacity for addressing the needs of NMT and for long-term capacity development in their own organizations. The funds would be allocated to those demonstrating commitment to the needs of NMT users.

² Scott Wilson, Op. cit.

1 INTRODUCTION

1.1 Background

During 1995 to 1999, with financial contribution from the Dutch Government, the SSATP carried out a program of Non-Motorized Transport (NMT) Infrastructure and Services in Kenya (Nairobi and Eldoret) and Tanzania (Temeke, ward of Dar es Salaam and Morogoro). The studies and pilot projects were carried out by an international team of consultants, lead by IHE, national teams in Kenya (team leader Tom Opiyo) and Tanzania (team leader Theo Rwebangira), and municipal staff teams in Dar es Salaam, Nairobi, Morogoro and Eldoret. Following the completion of this program, the consultants published a comprehensive book: “Productive and Liveable Cities: Guidelines for Pedestrians and Bicycle Traffic in African Cities”. It is based upon the experience of the NMT pilot program and is written as a guide for African urban transport professionals.

The SSATP then undertook an assessment of the above NMT program, the results of which were published in 2002.³ In 2003, the international consultants undertook a long-term impact evaluation of the NMT program.⁴ This report aims to: (a) comprehensively document the background to urban mobility in SSA, (b) describe the NMT pilot projects and their post-project monitoring, (c) document the various assessments of this program which were previously undertaken and (d) draw the “Lessons from experience” as a potentially useful instrument for the formulation and implementation of future NMT programs in SSA.

1.2 Contents of this report

The Executive Summary preceding this chapter is an overview and includes only the major elements of this study. This chapter briefly describes the contents of this study. The following chapters detail the rationale and the background for the discussion in the executive summary.

Chapter 2, Urban Mobility in Sub-Saharan Africa describes briefly the common characteristics of urban travel in SSA. In addition, it discusses (a) the general context of urban mobility which is a function of household incomes, (b) land use patterns with particular reference to where the poor live and where they work, (c) the conditions of poverty, dependence on NMT, and (d) the cost of public transport, trip lengths and the ability of the poor to make these trips.

³ Scott Wilson, Assessment of the Non-Motorized Transport Program in Kenya and Tanzania, SSATP Working Paper No. 71, November 2002.

⁴ M. de Langen, Test Interventions Implemented in Tanzania, Dar es Salaam (Temeke) and Morogoro, Long-Term Impact Evaluation, A Report to the World Bank, September 2003.

The discussion includes: (a) characteristics of road transport as the dominant urban transport mode, (b) poverty induced dominance of walking trips, (c) availability and cost of public transport and (d) modal splits in several SSA cities. It indicates that walking is the predominant mode in most SSA cities, followed by cycling in some cities.

This chapter also includes a brief discussion of several complex factors, which influence the urban transport environment. These factors are: (a) a fast growing urban population, (b) a continuing high incidence of poverty among the urban population, (c) the Central Business District (CBD) as the center of economic productivity, (d) changing role of the government, as a regulator than an owner of public transport, (e) the low density of cities and (f) the process of decentralization. These characteristics of the urban environment have a major impact on the urban transport environment and in addition, they constitute major challenges for the urban transport planners and decision-makers.

Chapter 3, Urban Mobility in Pilot Project Cities focuses on mobility conditions in the four pilot project cities. Lack of appropriate traffic management, absence of adequate infrastructure combined with lack of enforcement and traffic discipline have led to unnecessary traffic congestion and low levels of traffic safety. The discussion includes the urban mobility characteristics in the pilot project cities, modal choices and trip lengths.

Chapter 4, Institutional Aspects and Project Management describes the major institutional aspects, links to other projects and the organizational system for project management. The international consultants managed the project with the assistance of the national teams and the Pilot Project Units (PPU). The discussion includes various efforts to establish linkages to the ongoing World Bank projects (KUTIP and USRP) and liaison with projects funded by other international organizations. It also includes a discussion of the efforts by the project teams with regard to capacity building and knowledge management. The reasons for the failures and successes are detailed in this chapter.

Chapter 5, User Participation and Decision Making describes the user participation methods and the decision making process in the pilot projects. This participation was considered essential to the success of proper identification, prioritization and the subsequent implementation of NMT interventions. Focus group discussions were vehicles for identifying the perceptions of and attitudes towards mobility problems. Two user participation platforms were developed: General User Platform (GUP) and Local User Platform (LUP). The GUPs consisted of representatives of various user groups and became advisory groups to the local governments. The LUPs consisted of representatives living in the immediate vicinity of the proposed interventions and played major roles in the planning, design and implementation stages. The User Associations (UA) played a major role in determining priorities and the scope of improvements. This chapter details the role and effectiveness of the models adopted in the pilot projects.

A discussion of the awareness campaigns and publicity drives undertaken is also included. These campaigns were useful in making the community aware of the proposed NMT investments and drew public attention to various needs within each local community. They also led

to the successful participation of the local community as partners in development, who contributed ideas and free labor for some projects such as the Yombo River Pedestrian Bridge.

Chapter 6, NMT Pilot Projects discusses the interventions implemented in the pilot projects and the results of post-project monitoring of impacts. Mobility planning involved the preparation of mobility plans for pedestrians and cyclists, and the provision of spot improvements to NMT infrastructure. It also involved the building of NMT infrastructure and the introduction of traffic calming measures. The discussion details the NMT infrastructure interventions implemented in the pilot project cities, which included: (a) the construction of dedicated walkways, (b) missing bicycle and pedestrian links including NMT only bridges, (c) safe and convenient pedestrian road crossings including medians, and (d) appropriate intersection designs.

The traffic calming measures included (a) raised zebra crossings, (b) speed humps, (c) intersection corner re-designs, (d) road narrowing with bicycle slips and (e) the construction of bus bays. In addition to the details on the traffic calming measures in the four cities, this chapter also discusses the aggregate impacts of traffic calming.

Supply side interventions included measures to increase the ownership and use of bicycles. These measures consisted of: (a) pilot interventions for credit purchase of bicycles, (b) schemes for hire purchase of bicycles, and (c) promotion of cycling by women by introducing women's bicycles. These interventions also included: (a) special promotional sales of bicycles to women at discounted prices, (b) promoting bicycle hire, (c) teaching cycling to secondary school students and (d) efforts to systematize bicycle parking.

The PPU's conducted the post-project performance monitoring with the assistance of the national teams. The results indicated success stories and failures. These results are discussed in this chapter. A discussion of the general design and implementation issues is also included.

Chapter 7, Private Sector Participation discusses the successful efforts of the project teams to involve the private sector and the community at large, as partners in development. The discussion explores what was accomplished through the successful participation of the community. In addition, the role of the primary instruments, the User Participation Platforms, in achieving this participation is also discussed.

Chapter 8, Examples of Interventions details 16 examples from the pilot projects. All these examples are derived from the recent book by de Langen and Tembele.⁵ For each of the examples, this chapter provides details on (a) the background to the interventions, (b) their objectives, (c) what was implemented, (d) their impacts and (e) the costs and benefits. They are representative samples from the pilot project cities. The selected examples include: (a) walkways, (b) cycle tracks, (c) NMT missing links and NMT bridges, (d) pedestrian crossing islands, (e) medians, (f) speed bumps and raised zebra crossings, (g) network improvements, (h) bus bays and (i) intersection corner improvements.

⁵ De Langen and Tembele, Op. cit.

Chapter 9, Lessons from Experience synthesizes various lessons learned from the "pilot projects experience", which could be useful for formulating other future urban transport projects in SSA. The focus for the "Lessons" is policy formulation and project implementation. This chapter draws these lessons from the discussion in Chapters 2 to 8. It details the successes and drawbacks of (a) Urban mobility and modes of travel in SSA, (b) institutional aspects relating to the pilot project units, local capacity building, and linkages to other projects, (c) user participation programs and empowerment, (d) various physical improvements, traffic calming and supply side interventions and (e) private sector participation. Lessons are also drawn from the detailed examples discussed in Chapter 8. Finally it discusses the issue of sustainability of the improvements and an agenda for future research.

Chapter 10, References lists the major references and **Chapter 11, Electronic Sources** lists the electronic sources for mobility planning with an emphasis on NMT.

2 URBAN MOBILITY IN SUB-SAHARAN AFRICA ⁶

2.1 Background

The growth of African cities has been too rapid, compared to the capacity of the local governments to manage, absorb and finance the required urban transport infrastructure. In SSA, the youngest segment of the population accounts for more than 50 percent of the total urban population. This phenomenon places heavy demands on transport services, and has fundamental impacts on:

- A. Large scale travel flows at limited times,
- B. Fare policies, and
- C. Size and funding of fare reductions granted to this group.



Photo 2-1. Mixed traffic, uncontrolled street vending, lack of NMT facilities

Travel conditions in African cities are very difficult because of traffic safety issues, the quality of and accessibility to services, and air pollution caused by motorized transport. Currently more than half of all urban travel is by walk. Although the actual situations vary, urban transport systems in SSA have a number of common features:

- A. The majority of urban trips are still by walk;
- B. There is little or no coordination amongst the different modes of transport;
- C. The small-scale private sector is the major supplier of urban transport services and is under-capitalized and fragmented;

⁶ The discussion in this chapter is based on several publications: SSATP Working Papers No. 1, No. 35, No. 69 and No. 70. Urban travel data and photos are from World Bank project files.

- D. The regulatory system governing public transport is inadequate and ineffective in meeting the demand;
- E. Traffic accident rates are quite high;
- F. Roads are in poor condition;
- G. The skill levels of planning and regulatory personnel are inadequate or non-existent; and
- H. Low/poor enforcement of traffic laws due to corruption and inadequate human and financial resources.

In general, traffic conditions are chaotic. Uncontrolled parking often makes it difficult for passengers to find the appropriate buses. In addition, street vendors occupy an average of 25 percent to 35 percent of road space, worsening an already bad situation.



Photo 2-2. Buses, cars, pedestrians and street vendors share the same unregulated street space

These common characteristics of urban transport in SSA are compounded by factors arising from the general environment in which urban transport is evolving:

- A. The rapidly growing urban population,
- B. Continuing high incidence of poverty among the urban population,
- C. The impact of the city as the center of economic productivity,
- D. The evolution of the role of government,
- E. The low density of cities,
- F. The process of decentralization, and
- G. Poor land use planning and ineffective development controls together with the lack of any linkage to urban transport planning.

2.2 Urban Poverty

In 1992, about 40 to 50 percent of the population in SSA was living below the poverty thresholds.⁷ In 2002, the situation was still just about the same. The persistence and magnitude of urban poverty constitutes a major challenge in the context of balancing the costs and benefits, user pay aspects and the prioritization of urban transport investments.

Poverty is the dominant feature of the urban transport sector in SSA, both for the users and for those who find employment in it. Any improvement travel conditions will have a positive economic impact on urban productivity, more particularly that of the urban poor.

An efficient and effective urban transport system is a powerful tool for improving the efficiency and accessibility of the labor market, and providing better access to education and health services. A key challenge is, therefore, to develop a reliable and affordable urban transport system with satisfactory conditions of safety. At this time, no city in SSA meets all these criteria fully.

The cost of urban transport is a significant part of household expenditures. It accounted for 12.4 percent of household expenditures in Abidjan (1993), 13 percent in Ouagadougou, Lomé and Cotonou (1996) and 17 percent in Yaoundé (1996). From 1993 to 2002, the overall household outlays on transport in Abidjan increased by 20 percent, despite the 1994 devaluation of its currency. A study conducted in Dakar in 1999 indicates that the urban poor spent as much as 28 percent of their household incomes on transport.⁸ The increasing transport expenditures produced exacerbating phenomena such as: (a) an increasing number of trips made by walk, (b) fewer days on which people travel, and (c) a reduction in the average number of trips, especially in the larger cities.

2.3 Traffic Congestion and Traffic Safety

Road transport is the dominant transport mode in African cities. However, the inadequacy of road capacity, results in traffic congestion and in traffic accidents, damage to the city's economy and increasingly negative environmental impact. For example, it is estimated that in the city of Dakar (2.3 million inhabitants), 1.0 million hours are lost every working day due to traffic congestion.⁹

Traffic congestion, noise and air pollution are frustrating ingredients of city travel in many parts of the world. However, few areas around the world can match the urban transportation problems faced every day by major cities in SSA. Traffic congestion, for both motorized and

⁷ SSATP Working paper No. 35, p. 6.

⁸ C. Kane and X. Godard, Performance of Urban Transport Modes and the Needs of the Urban Poor, SITRASS, November 2001.

⁹ Ibid.

non-motorized transport within these cities, is the basic cause for impeding commerce, increasing noise and air pollution, and some times making it difficult for the cities to provide even the basic services. As well with continuing urban population growth, the urban transportation systems are further congested. As the prospects for improvement become more remote because of lack of sufficient resources, these clogged transportation systems impede economic development, making it harder for people, especially the urban poor, to find work and stay employed.

There is more than just inconvenience and inefficiency involved on the urban roads of SSA. The situation on these roads can quickly become deadly. Accidents between vehicles and pedestrians are all too common and their frequency is growing rapidly. Between 1968 and 1998, road fatalities in Africa increased by 400 percent, pedestrians and public transport passengers making up the largest group of accident victims.

A recent appraisal of Road Safety Initiatives in five African cities, carried out by the SSATP, shows that pedestrians and public transport passengers are the largest group among the fatalities, amounting to about 30 to 40 percent each.¹⁰



Photo 2-3. Lack of pedestrian facilities, causing safety challenges

2.4 Public Transport

The supply of transport services in Africa's largest cities, since 1989, has been characterized by a significant decline of public transport companies (Abidjan, Dakar, Harare, Nairobi, Addis Ababa and Dar es Salaam) as well as the disappearance of some companies (Yaoundé, Conakry,

¹⁰ SSATP Working Paper No. 35, p. 7.

Pointe Noire, Brazzaville and Libreville) in favor of the so-called informal micro-enterprise sector. While the size of the urban transport market is increasing because of population growth, the market share of the big companies is declining steadily to the advantage of the micro-enterprises. In Abidjan, SOTRA's market share was 47 percent of the urban trips in 1988, declining to 27 percent in 1998. Over the same period, small operators (gbakas and woro-woros) saw their market share increase from 19 to 49 percent. In Dakar, small operators increased their market share from 18 percent in 1980 to 78 percent of motorized travel in 1998. The generalized decline and even the disappearance of traditional transport companies in favor of the small-scale private sector is a reflection of a persistent crisis in urban transport systems. It also reflects the failure of these companies to adjust to African socio-economic realities.



Photo 2-4. Disorganized and unruly bus-bays obstructing dedicated walkways and cycling tracks

In most cities, the private sector now provides virtually all public transportation: minibuses, collective taxis and a host of other types of public transport. Their growth has been dramatic. Most private bus and minibus services are small enterprises or family businesses comprising of two or three buses, owner operated or leased on a daily basis, Cars Rapides (Dakar), Woro Woros (Abidjan), Durumi (Bamako), Molus (Nigeria), Matatus (Nairobi), Dala Dalas (Dar es Salaam) and Boda-Boda (Kampala). Most are secondhand vehicles, financed through personal savings and a few through cooperative mechanisms. They are operated, in most cases, without any consideration for fleet renewal.

Waiting times at bus stops in many cities could be as much as 30 to 45 minutes and a journey in congested areas could take as long as 1-2 hours just to travel 8 or 10 kilometers. In 1998 in some areas of Lagos, bus stop waiting times were 45 minutes and depending upon location and time, it could take as long as 2 hours to travel a distance of only 8 kilometers.¹¹

2.5 Low Mobility

More than 50 percent of all trips in urban areas are by walk. This situation, which affects mainly the most disadvantaged urban population groups, can be traced back partly to the failure of the mass transit companies in the 1980s and their high fare levels. More often than not, the poor cannot afford mass transit, which is beyond their "ability to pay". The citizens hardest

¹¹ SSATP Working Paper No. 35, p. 5.

hit by this dysfunction or the high cost of urban services (including transport costs) are the poorest groups of city dwellers.

Table 2-1. Mobility and modal choice in SSA cities

City	Country	Mobility (trips/person/day)	Mode Choice, % of Total Trips			
			Walk	Bicycle	Public Transport*	Private Motor- ized Transport**
Morogoro	Tanzania	1.7	67	23	12	4
Dar es Salaam	Tanzania	1.9	47	3	43	7
Nairobi	Kenya	2.2	47	1	42	7
Eldoret	Kenya	2.7	48	12	24	16
Kinshasa	Congo	2.2	70		20	10
Addis Ababa	Ethiopia	4.9	70		26	4
Bamako	Mali	3.1	60	2	17	21
Ouagadougou	Burkina Faso	3.8	42	10	3	45
Harare	Zimbabwe	N/A	63	1	16	20
Niamey	Niger	N/A	60	2	9	32
Dakar	Senegal	3.2	81	1	17	1

* includes privately operated minibuses and buses. **includes motorcycles, taxis and employer buses.

Table 2-1 shows the mobility and modal choice in selected SSA cities. Mobility varies from a very low of 1.7 in Morogoro, 1.9 in Dar es Salaam, 2.2 in Kinshasa and Nairobi, 2.7 in Eldoret, 3.1 in Bamako, and 3.2 in Dakar. Several SSATP studies indicate that low mobility leads to low urban productivity. Much of this low mobility is a result of urban poverty in SSA.¹² Productivity can increase with improvements to NMT modes, used predominantly by the poor.

2.6 Non-Motorized Transport: Walking, the Predominant Mode

In SSA, the pedestrians account for about 50 percent of all daily trips. In spite of this, segregated traffic facilities for pedestrians and NMT are mostly non-existent. SSATP Studies conducted during 1992-2002, as shown in Table 2-1, indicate that walking is the predominant mode in SSA cities. Walking accounts for 81 percent of all trips in Dakar, 70 percent in Addis Ababa and Kinshasa, 67 percent in Morogoro, 63 percent in Harare, 60 percent in Bamako and Niamey, 48 percent in Eldoret, 47 percent in Nairobi, 45 percent in Dar es salaam and 42 percent in Ouagadougou. Even very basic NMT infrastructure facilities do not exist in most cities. The welfare of pedestrians is often sacrificed to planning for the faster flow of vehicles. In the planning and management of infrastructure investments, the imbalance between motorized and non-motorized transport can be addressed by a clear definition of the rights and responsi-

¹² John Howe and Deborah Bryceson, Poverty and Urban Transport in East Africa: Review of Research and Dutch Donor Experience, (Étude mobilité urbaine et transport non motorisé des ménages les plus pauvres - PUTEA), 1993-1999, SSATP Report, December 2000.

bilities of pedestrians and cyclists in traffic flow, as well as building appropriate NMT infrastructure commensurate with current and future traffic volumes.

Cycling is not popular in African cities except in a few like Ouagadougou. However, in medium size cities, it is quite common. Data (Table 2-1) indicate that cycling trips accounted for 23 percent of all daily trips in Morogoro, 12 percent in Eldoret, 10 percent in Ouagadougou, 6 percent in Dar es Salaam, 2 percent in Bamako and Niamey, and only 1 percent in Nairobi.



Photo 2-5. Severe lack of pedestrian infrastructure, even for crossing streams



Photo 2-6. Handcarts used for goods transport



Photo 2-67 Bicycles are common, but their mode share is still small

3 URBAN MOBILITY IN PILOT PROJECT CITIES

3.1 Urban Mobility in Dar es Salaam and Nairobi

Mobility levels in the pilot project cities (Temeke Ward of Dar es Salaam, Morogoro, Nairobi and Eldoret) are shown in Tables 3-1 and 3-2. Dar es Salaam and Nairobi are large cities with populations of just under 2 million, with long trips, high travel times, high cost of transport, and the absence of proper infrastructure facilities for walking and cycling, and persistence of poverty for the vast majority of the population. Nearly half the trips (47 percent) are by walk and a little more than 40 percent by public transport, the majority of which were by minibus. These mobility rates are very low compared to >3.0 trips/person/day in other developing countries outside SSA.¹³ The persistence of low mobility is a major challenge for those seeking employment and thereby seeking to increase their household incomes.

Eldoret and Morogoro are smaller towns with populations of just under 150,000 inhabitants. Urban mobility was a low of 1.7 in Morogoro and 2.7 in Eldoret.

Table 3-1. Urban mobility characteristics in Dar es Salaam and Nairobi

Urban Mobility	Dar es Salaam	Nairobi
Population in millions	2.2	2.14
Population Growth Rate per year	5%	2.14%
Area Sq. Km	530	696
National Income per capita in USD	245	350
Car Ownership per 1,000 persons	26	20
Urban Mobility, daily trips per person	1.96	2.24
By walk	47%	47%
By Bicycle	3%	1%
By Public Transport	43% (98% Minibus)	42% (70% Minibus)
By car and motorcycle	7%	10%

Source: SSATP WP No. 70 and SSATP Pilot Projects, 1994 and 1996 Household Surveys

Share of cycling was only 3 percent in Dar es Salaam and 1 percent in Nairobi. Lack of dedicated NMT infrastructure facilities, fear of fatal traffic accidents and lack of financial ability to own a bicycle are the main impediments to higher bicycle use in both cities.

¹³ SSATP Working Paper No. 71, Table 6.

Table 3-2. Mobility and modal choice in pilot project cities

City	Urban mobility, daily trips/person	Modal choice % of all trips				Source
		Walk	Cycle	Public transport*	Private motorized transport**	
Temeke (DSM)	1.96	47	3	43	7	De Langen and Tembele
Morogoro	1.7	67	23	12	4	
Nairobi	2.24	47	1	42	10	SSATP WP #70
Eldoret	2.7	48	12	24	16	J. Howe, PUTEA 2000

* includes both privately and publicly operated services, **includes motorcycles, taxis and employer buses.



Photo 3-1. Bicycles are common, Their mode share is small



Photo 3-2. Motorcycles and air pollution in Ouagadougou

Trips by car accounted for 7 percent of all daily trips in Dar es Salaam and 10 percent in Nairobi. These vehicles are affordable by only the top income earners or employees of the government and large enterprises. This situation is unlikely to change during the next decade.

Accident rates are very high: 58 fatalities per 10,000 people in Dar es Salaam and an extremely high of 97 in Nairobi. Measured another way, fatalities were 46 per 100,000 vehicles in Dar es Salaam and a very high rate of 321 in Nairobi. Fatalities/million veh km were 174 in Dar es Salaam and a whopping high of 321 in Nairobi. These fatality rates are very high, compared to about 1.2 to 1.8 fatalities per 100,000 vehicles in the EU countries.¹⁴

¹⁴ WHO statistics on EU countries and SSATP Working Paper No. 70 for Dar es Salaam and Nairobi.



Photo 3-3. Signal System out of order in Nairobi
Pedestrians taking chances

Because of traffic congestion, mixed traffic conditions, lack of enforcement of traffic laws, driving without due regard to safety and the rules of the road, the general lack of adequate road space for all modes, and other reasons discussed in Chapter 2, vehicular traffic speeds for all modes are quite low and traffic safety levels are very low. Typical door-to-door travel speeds in Dar es Salaam and Nairobi in 1998 were:¹⁵

➤ Walking	3-5 km per hour
➤ Cycling	10-12
➤ Motorcycle/moped	15-20
➤ Car	15-17
➤ Standard Bus	8-10
➤ Minibus	10-12

3.2 Dar es Salaam

Urban mobility, for middle and low-income families, was 1.96 trips per person per day.¹⁶ Many people are immobilized around their homes, at this low mobility rate. For the most important trip of the day, 45 percent walked the entire distance while 44 percent used the bus. A majority of the walking trips (57 percent) within 3 kilometers, showing the limited range of the walking trip.

¹⁵ WB Project files, SSATP Pilot Projects.

¹⁶ T. Rwebangira and J. Nguma, Dar es Salaam Action Plan for Urban Mobility and NMT, SSATP Report No. 14, 1994, as referenced in SSATP Working Paper No. 70.

One of the main reasons for this low mobility is that a large number of residents of Dar es Salaam cannot afford the bus fare, even for a single trip. In addition, most people cannot afford to own a bicycle, which costs about four times their monthly minimum wage. It was not possible to increase the modal share of motorized trips, including public transport, due to serious resource constraints such as lack of capital, land availability and the high cost of motorized transport for the majority of the residents. At the same time, it is very important that the level of mobility, for the majority of the people, should be increased so that they can participate in a wide range of economic activities.



Photo 3-4. Typical bicycle load in Dar es Salaam

Safety is the most important reason not to cycle on the main corridors of Dar es Salaam or even to consider cycling as a potential mode for such a trip. Unsafe traffic conditions have an overall negative effect on mobility. Fear of road fatal road accidents has made it more difficult for anyone to use a bicycle on a trip to the CBD. This is attributed partly to the high speed of motorized traffic and partly to the poor driving behavior of Dala Dala drivers. The same reason has curtailed walking along the major corridors because of difficulties associated with crossing the road at various intersections. Furthermore, there is a serious lack of NMT infrastructure deterring people from using the NMT modes. Most serious is the absence of continuous routes for cycling or walking in many areas of Dar es Salaam. In addition, what little NMT space is available (footpaths and cycle lanes) is obstructed or occupied illegally by parked cars, and both legal and illegal kiosks.¹⁷

¹⁷ SSATP Working Paper No. 70, Section 10.

3.3 Nairobi

In 1994, as part of the pilot projects, household surveys were conducted in Nairobi and Eldoret.¹⁸ Data from this survey, included in Table 3-1, indicates that 47 percent of all trips were by walk, only 1 percent by bicycles, 42 percent by public transport, 7 percent by private car and 3 percent by company cars. Since a trip by public transport starts and ends with a substantial walk, then the modal share for walking is much higher than officially stated. The expense of public transport and lack of safe alternatives determines that walking is the only personal travel option for the urban poor. For a growing proportion of the population, walking trips are becoming longer as cities expand and at the same time, employment opportunities are centralized and their homes moved to the periphery.

Unfortunately, bicycles have become insignificant in the largest cities due to the increasingly hostile and unsafe environment created by motor vehicles and the absence of dedicated infrastructure. At present, bicycle use is relatively insignificant in Nairobi, a marked contrast to the situation two or three decades ago. In the eastern part of Nairobi, 11 percent of the households owned one or two bicycles. This apparently high ownership rate is in contrast to the trip rates of 1 percent. These households own bicycles primarily for children's recreation and for carrying goods. The apparently low utilization rate quite possibly reflects the fear people have about using bicycles in heavy traffic.



Photo 3-5. Walking to work in Nairobi in 1994

¹⁸ O. Mairura et al, Nairobi Household and Corridor Survey Analysis, SSATP NMT Report, 1994.

3.4 Temeke (A ward of Dar es Salaam)

Mode choice matrix for Temeke is shown in Table 3-2. Walking is the dominant mode of transport both in Temeke and Morogoro. Temeke ward of Dar es Salaam (pilot project area of DSM) had a population of 150,000 people. It is an old low-income area in the middle of Dar es



Photo 3-6. A low speed roundabout in Morogoro, 1996

Salaam, dissimilar to those new low-income areas at the periphery. The number of walking trips >5 kilometers is only 4 percent of all trips (8 percent of all walk trips). This is primarily because for most of the people in Temeke, their work places are within 7 kilometers of their homes. Those in low-income areas at the periphery, travel much longer distances. Cycling accounts for only 3 percent of all trips. This could be because of the very unsafe traffic conditions existing for cyclists in Dar es Salaam.¹⁹

3.5 Morogoro

Morogoro has a population of 200,000 people. While Temeke is part of a major metropolis, Morogoro is a medium-size city. Two-thirds of all trips (67 percent) are by walk. Cycling is the second most important mode (23 percent of all trips) in Morogoro. However, most of the poor cannot afford to own a bicycle. The main limiting factor for the increased use of bicycles in Morogoro is their affordability.²⁰ This is typical of the medium size cities of SSA.

3.6 Eldoret

Eldoret, like Morogoro, is a medium-size city. Nearly half the daily trips (48 percent) were by walk. Cycling accounted for 12 percent of the daily trips. Mobility in Eldoret was 2.7 trips/person/day, though quite low and yet higher than in Morogoro. Like in Morogoro, incomes were low enough to be a deterrent to bicycle ownership.

3.7 Mode choice and trip length: Temeke and Morogoro

Tables 3-3 and 3-4 show the mode choice and trip lengths for Temeke and Morogoro. In Temeke, which is in the older part of the city near the CBD, nearly 50 percent of the walking trips were within 2 kilometers, which is a reasonable walking distance of 30 minutes depending upon traffic mix and walkway conditions. Another 40 percent of walk trips were within 5

¹⁹ De Langen and Tembele, *op. cit.*, p. 79.

²⁰ *Ibid.*

kilometers and only 10 percent at >5 kilometers. Cycling was only 4 percent of all trips in Temeke. Public transport trips accounted for 43 percent of all trips. Most of these (63 percent of these) were of >8 kilometers.

Table 3-3. Mode choice and trip lengths in Temeke

Mode	Trip Length in Km, % of total trips				Total %
	0-2	2-5	5-8	>8	
Walk	23	20	4	0	47
Cycle	1	2	1	0	4
Public Transport	2	6	8	27	43
Car	0	1	1	4	6
Total	26	29	14	31	100

Source: De Langen and Tembele, Table 8.6.

Table 3-4. Mode choice and trip lengths in Morogoro

Mode	Trip Length in Km, % of total trips				Total %
	0-2	2-5	5-8	>8	
Walk	27	33	7	0	67
Cycle	2	8	4	3	17
Public Transport	1	3	1	7	12
Car	0	0	2	2	4
Total	30	44	14	12	100

Source: De Langen and Tembele, Table 8.7.

In Morogoro, about 40 percent of the walking trips were within 2 kilometers, a reasonable walking distance of 30 minutes depending upon traffic mix and walkway conditions. Another 50 percent of walk trips were within 5 kilometers and only 10 percent at >5 kilometers. Cycling was the second important mode of choice with 17 percent of all trips in Morogoro. Public transport trips accounted for only 12 percent of all trips.

NMT (Walk and cycle) trips were the predominant modes: 51 percent in Temeke and 84 percent in Morogoro. In Temeke, the availability of public transport and the central location allows public transport to play a major role. However, in Morogoro, typical of medium size cities, trip distances are smaller and people cannot afford public transport. This leads to a smaller role for public transport and a predominant role for NMT.

4 INSTITUTIONAL ASPECTS AND PROJECT MANAGEMENT

4.1 Links to Other Projects

The NMT Program was required to develop strong links with the Kenya Urban Transport Infrastructure Program (KUTIP) and the Tanzania Urban Sector Rehabilitation Program (USRP), two major World Bank-funded infrastructure projects. The intention was to ensure that the measures, which cater to NMT users, were incorporated into the sub-projects implemented within these two major programs. However, aside from some small infrastructure works, awareness raising and training, the NMT Program had a much smaller impact on KUTIP and USRP than had been originally thought.

The KUTIP project designs in Nairobi were well advanced by the time the International Consultants tried to exert influence. The government and the World Bank both resisted the redesign due to the risk of delays. In addition, a breakdown in communication had also occurred between the Nairobi City Engineer and the team managing KUTIP in the Ministry of Local Government. This restricted the ability of the Urban Mobility Unit (UMU), established within the City Engineering Department, to influence the designs. However, some later KUTIP projects in Nairobi did have specialized NMT input to the design, but not all the recommendations of the NMT consultant were adopted.

The Consultants conducted training courses on non-motorized transport for engineers and planners from government, local authorities and private consultants. This training contributed to the incorporation of NMT measures into KUTIP designs in several centers in Kenya. Works funded by KUTIP included improvements to road shoulders that act as pedestrian walkways, and tree planting along NMT routes.

The USRP did not fund any road works in Dar es Salaam. Major road rehabilitation was funded by the Japanese Government. The Japanese contractor engaged in these works was fortuitously involved in constructing some of the pilot NMT traffic calming interventions, which resulted in the inclusion of significant NMT measures throughout the wider rehabilitation program. Major road rehabilitation, funded and implemented by the Japanese Government in Dar es Salaam, benefited from NMT measures due to the involvement of the Japanese contractor in the construction of the NMT pilot interventions in Temeke municipality.

The Morogoro PPU, with the assistance of the National Team, persuaded two major World Bank-funded programs, namely the Integrated Road Project (IRP) and the Urban Sector Road Program (USRP) to include NMT infrastructure within their projects in Morogoro. The PPU and the National Team helped the two programs with the designs for NMT infrastructure. The final design included separated pedestrian and cycle tracks, raised zebra crossings, Dala Dala stops, and open drains separating motorized vehicles from NMT. On sections of road with a

reserve greater than three meters, physical segregation was achieved by the construction of pre-cast concrete open drains, raised curbs and bollards. Raised zebra crossings were also constructed but in some instances badly located. The drains were performing well, with no silting problems in 2002.



Photo 4-1. NMT facilities built under the USRP in Morogoro

By 2003, a substantial number of the roads in Morogoro now have NMT infrastructure facilities and traffic calming aspects. The 3 kilometers long Turiani Road has been rebuilt with a 2.0x3.0 meter carriageway with open drains, a separate bi-directional cycle track, and a walkway on one side of the road. Traffic condition has improved very significantly, in a well-balanced way, between all modes.²¹ This indicates that over time, it is possible to achieve the implementation of NMT facilities as experience and knowledge change the attitudes of the decision-makers and professionals.

Links to other major urban transport projects are necessary and important but very difficult and complex to implement successfully. However, this is not an impossible task. These linkages should be established early on at the planning stages, with clear formal mandates. There should be a clear understanding by both project teams that such linkages are not only useful but also important. The pre-requisite to successful linkages is the ability to convince the lending and donor agencies of the need and importance of cooperation. At the operational level, it is important that the Task Team Leaders of the linked projects are sensitive to and interested in building NMT infrastructure facilities.

²¹ Marius de Langen, Test Interventions in Temeke and Morogoro, Long Term Impact Evaluation, Report to the World Bank, September 2003.

4.2 Management of the Pilot Projects

International Team and National Team

The SSATP Program appointed a team of International Consultants (IT), Delft University- IHE in the Netherlands to manage the pilot projects, in close liaison with the local authorities. Its primary role was to support and assist the local authorities in the pilot project cities. This included overall coordination of the projects, reporting on progress, managing the project funds, raising awareness, providing training and technical assistance. The consultants were required to establish links with the national and local governments, as well as with other projects such as the KUTIP and USRP. In addition, they were required to ensure regional cooperation and dissemination of lessons learnt.²²

They were responsible for controlling project finances, technical inputs to the designs of NMT infrastructure, training, advising the local authorities on management systems, reporting and dissemination of lessons learned. An assessment conducted by the World Bank indicates that the consultants carried out their responsibilities in accordance with their terms of reference.²³

The International Team appointed a National Team (NT) of Consultants to assist them and work closely with the local authorities. The NT reported to the IT. The NT consisted of experts from the universities of Nairobi and Dar es Salaam and consisted of an engineer, a planner and social scientist in both cases. The NT had no direct links with or reporting responsibilities to the World Bank. Their primary role was to provide technical support to the local authorities, in the implementation of the pilot projects.

Planning for and the implementation of NMT interventions was based on the "Mobility Planning Approach", which sought to put road users at the center of the planning process. The sustainability of the pilot project activities depended on the local authorities and the users occupying the center of the implementation framework.

Pilot Project Units

Pilot Project Units (PPUs) were established within the local government structure to implement the pilot interventions. The PPUs were the nerve center of the project being responsible for implementation. They were located within the municipal organizational structure under the Municipal Engineering Department, to whom they were answerable. They were responsible for the identification, design, construction and monitoring of spot interventions. They were also required to ensure user participation in this process.

²² SSATP Urban Transport Component: Non-Motorized Transport, Terms of Reference Phase II, Part 1, January 1995.

²³ Scott Wilson, Op. cit., p. vii.

PPUs had the following roles:

- A. Development of User Participation Modules
- B. Formation of User Participation Groups/Platforms
- C. Participation in NMT problem analysis and prioritization
- D. Participation in the planning, design, implementation and monitoring of interventions
- E. Organization of activities around NMT awareness, educational and promotional campaigns within the municipal area
- F. Dissemination of project findings at various forums, including professional gatherings and seminars locally and internationally
- G. Liaison with the relevant national government ministry e.g. Ministry of Local Government on matters specific to the project and related to NMT issues in urban areas.

There was noticeable disparity between the national teams and the PPU in terms of professional experience, remuneration and attitudes towards NMT. PPU staff was aware of the fact that the pilot projects and the consultants (national and international teams) were well funded by the international donor agencies and the World Bank. However, they were not privy to budget details and at times, this caused resentment. An important lesson was learned: to achieve success, it is important that the consultants are transparent from the beginning regarding available project funds and how these funds would be utilized. There should be no false promises or expectations. These conditions would most likely stop unnecessary suspicions later on in the project cycle.

The PPU, being responsible for implementation, were the nerve center of the project. They were located within the municipal organizational structure under the Municipal Engineering Department and reported to the city engineer. The PPU were later named the Urban Mobility Units (UMU) because they subsequently assumed a more encompassing role. Their staff were from different professional backgrounds (an engineer, a town planner and a social scientist). In Nairobi, Eldoret and Morogoro, the municipal engineer responsible for Transportation/Traffic headed the PPU. In Temeke, the head of the PPU was a social scientist and a staff member of the city council rather than a regular line employee.

The effectiveness of the four PPU varied, given the contrasting backgrounds of their leadership. For example, the engineers who headed the PPU tended to be proponents of orthodox and conventional approaches. NMT modes were factored into the traffic matrix only when NMT traffic became a negative externality to the motorized traffic. Public participation in the conceptualization, planning and implementation of engineering interventions was either unheard of or took a back seat. Hence, the acceptance of intervention proposals designed to give these issues prominence was slow.

Nairobi flatly refused to implement some interventions, even after the World Bank assured that the physical works would be removed if they did not improve the existing situation. They considered the proposed interventions to be too disruptive to motorized transport. The munic-

pal engineers were concerned with the political backlash, which could occur if the interventions did not work well. In addition, the traffic problems on Jogoo Road (targeted for NMT interventions) were so serious that the municipal engineers thought that implementing the NMT interventions would only make the traffic problems worse. They had no previous experience with similar interventions and as such, they felt that they could not simply try them out if the consultants could not provide them with any successful African examples to dispel their genuine concerns. In addition, their priorities were to keep the motorized traffic moving smoothly, on this major thoroughfare of Nairobi.

In Temeke, the PPU was headed by the social scientist (a staff officer of the City Council and not a regular line employee of the city), committed to the success of the project and unhindered by the natural conservatism of some engineers and planners. In addition, the proposed interventions in Temeke were not on major arterial streets and as such, easier to implement without political interference. Once the social scientist was convinced of the merits of the project, she steamed ahead with gusto and enthusiasm because she could easily relate to these new perspectives. Consequently, the interventions (one of three municipalities comprising Dar es Salaam) were rapidly implemented. When controversy emanating from the automobile lobby threatened to derail implementation, the PPU team was able to defend the interventions quite successfully.

The PPUs in Eldoret and Morogoro were led by engineers and the acceptance of intervention proposals made by the NMT Consultants was slower than in Temeke. The Morogoro municipality, at the first sign of complaints from motorists, removed all of the test interventions under the pretext that they wanted to reseal the pavement.

Despite their crucial role in the implementation of the pilot interventions, the PPUs were still given limited control over project activities. Some of them were involved in the design, costing, selection and implementation of the spot intervention works. However, they were not privy to how much money was available for the activities including consultant fees, travel expenses or per diem. They relied heavily on the National and International Consultants for direction, technical input, the planning and coordination of activities and approval of funding.

Remuneration for municipal officials in SSA is relatively low, particularly in comparison to the private sector. What tends to happen is for these officials to moonlight. Being seconded to the PPU entailed extra responsibilities, which had the effect of lessening the time for moonlighting. Without incentives from the project, the commitment of the officials to the extra responsibilities demanded would be immediately in doubt. Therefore, financial incentives were provided to PPU members and their commitment to the project was also enhanced through:

- A. Provision of computer equipment,
- B. Opportunities to be trained in the use of computers, and
- C. Access to secretarial and other support staff

Some officials within the municipalities questioned the provision of incentives to the PPU staff. Within the PPU itself, the project leader earned more than the other members. These rumblings, which appear to have had deeper roots in Nairobi, did not constitute a significant threat to the running of the PPUs or their effectiveness. Nevertheless, these incentives appear to have been successful in motivating PPU members. However, there was still some resentment against the Consultant's National Team members who were better rewarded than the PPU staff for their participation.

All the four PPUs were dissolved upon completion of the pilot project implementation and after a short period of monitoring. The two areas of weakness of the projects were:

- A. Lack of true empowerment of the local authorities participating in the project (the NMT Consultants were firmly in charge of the process); and
- B. Lack of effective dissemination of the lessons learned.

4.3 Management Structure

Figure 4-1 represents the management structure for the NMT Program. The structure adopted was essentially *top-down*, which was probably necessary to ensure that deadlines were met and physical outputs achieved. However, the sustainability of the pilot activities depended on the local authorities and the users occupying the center of the implementation framework, and being in charge of the development process. This certainly met the deadlines, resulted in an increased public awareness of NMT issues and facilitated the testing of a wide range of NMT measures. However, it quite possibly undermined the progress towards the other core objectives of the project, namely institutional development and capacity building within the local authorities.²⁴

Figure 4-2 represents how the management structure could have been structured and functioned. This structure shows the local authorities and the users closer to the center of the processes for implementing the NMT program and managing the interface between the NMT Consultants and other major investment programs, such as KUTIP and USRP. One of the important objectives of local authority control over the interventions is to balance potentially conflicting approaches championed by various stakeholders with the actual needs of the residents. The main reasons for the difficulties encountered in Nairobi, both for NMT interventions and meaningful coordination with the KUTIP program are discussed above. However, a key constraint was the effective sidelining of the local authorities through the organizational structure put in place for both the NMT Program and KUTIP.²⁵

²⁴ Scott Wilson, Op. cit.

²⁵ Ibid. p. 47.

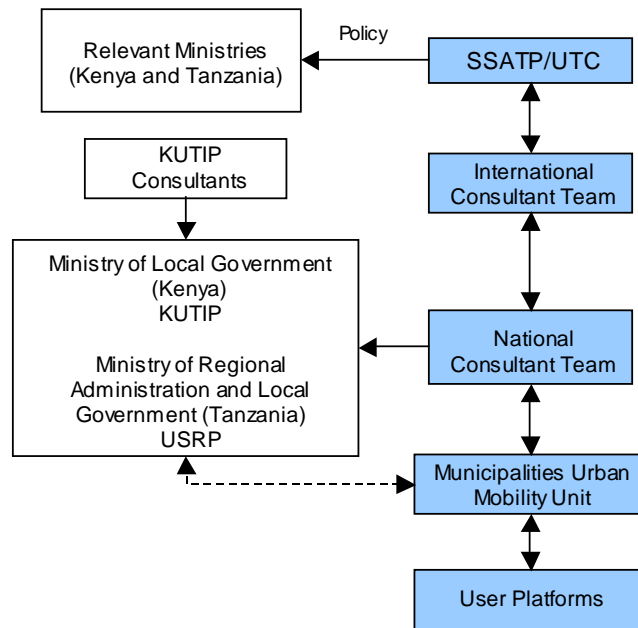

Figure 4-1. NMT pilot project management structure

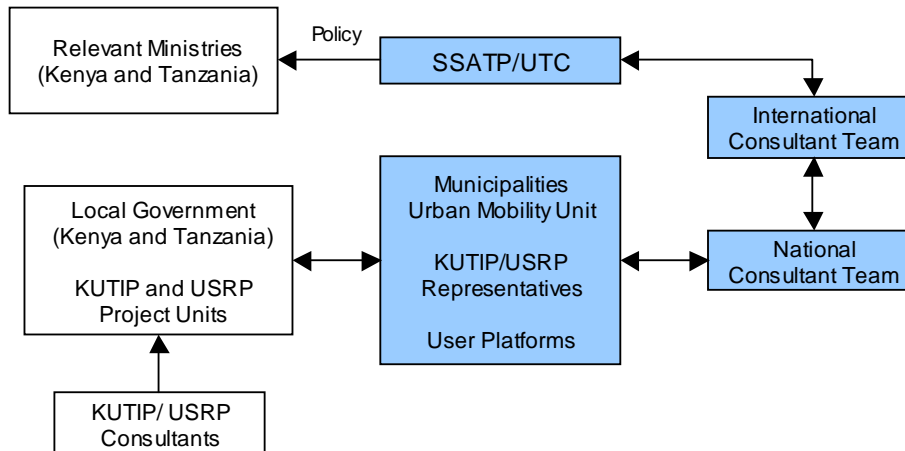

Figure 4-2. Alternative NMT pilot project management structure

4.4 Capacity Building

Municipal authorities require systematic training and organizational support over a long period of time to enable them to develop the *corporate knowledge*.

- A. To identify mobility problems,
- B. To plan and design a program of interventions and transport policies, and

C. To supervise the implementation by contractors and consultancy firms.

The long-term objective of the NMT pilot projects was to facilitate the establishment and reinforcement of the municipal capacity to design and implement affordable urban mobility policies, in particular non-motorized transport policies targeted at the urban poor. The pilot projects were to contribute towards achieving this objective through the practical testing of NMT measures and policies, institutional development and capacity building in local authorities and training of professional staff. Training programs and access to national and international consultants were certainly positive instruments of building local capacity.

The lack of existing capacity within the local authorities and of organized user groups in the project areas were clearly constraints to achieving the institutional and capacity building outputs. The local authorities needed to take charge of the process from the outset and allowed to progress at their own pace within their resource constraints. Capacity building in the local authorities was limited to awareness raising, the training of some municipal staff and practical experiences with the performance of the spot interventions.

Significant work was done on testing spot interventions to support NMT, but the proportion of the overall budget spent on the physical interventions was small. Therefore, the experience gained was the primary output of the project and the main contributor to the long-term objectives. The amounts spent, in particular for the high cost of consulting services, will only be justified if further progress can be made to influence government policy to undertake similar interventions on a wider basis throughout Sub-Saharan Africa. The challenge is to bring appropriate NMT infrastructure planning into government policy and design aspects into urban road design manuals, with an equivalent importance similar to current standards required for motorized transport.

There is a need for more engineering input to the design and testing of interventions. Some solutions that work in the developed world were shown to be unsuccessful in those cities that lack capacity to maintain the infrastructure and to enforce the law. The second main output of the pilot interventions was a significant increase in awareness amongst politicians, planners, engineers and the public, of the importance of addressing the needs of non-motorized transport.

The primary thrust to providing for NMT infrastructure was based on the mobility planning approach, which sought to put road users at the center of the planning process. However, the pilot project activities were constrained by short time frames and the need to show results. Therefore, NMT Consultants (international and national teams) had to take charge of the process. This certainly met the deadlines, resulted in an increase in public awareness of NMT issues and allowed for the testing of a wide range of NMT measures. However, it quite possibly undermined the progress towards the other core objectives of the project, namely institutional development and capacity building within the local authorities.²⁶

²⁶ Ibid.

The lack of existing capacity within the local authorities and of existing organized user groups in the project areas were clear constraints to achieving the institutional and capacity building outputs. The local authorities needed to take charge of the process from the outset and allowed to progress at their own pace within their resource constraints.

4.5 Knowledge Management

There is a substantial lack of effective dissemination of the lessons learned. A significant proportion of the project reports were not available to the World Bank assessment team in 2002, so it was not possible to verify compliance with all of the detailed requirements of the NMT Consultant's TOR. "The Guidelines for Pedestrian and Bicycle Traffic in African Cities", written and published by the consultants after the project ended, is the only comprehensive record of the various NMT activities. This is the primary source of written information.²⁷ These guidelines provide comprehensive information relating to the project but were produced in the format of a textbook. They include few details of the delivery of outputs in relation to the original program of activities.²⁸

The pilot interventions have generated a significant body of technical information on the planning and implementation of NMT measures. These studies show that simple cost effective measures can be implemented to relieve severe pressures on existing urban transportation infrastructure. Important lessons were learned on how to involve users at all stages of the project cycle. Awareness amongst politicians planners and engineers of the importance of considering the needs for non-motorized transport in the management of urban transport networks, increased. The assessment of the pilot projects carried out by the World Bank in 2002, was based on a review of the literature made available to the assessment team and interviews with key informants. An attempt was made to seek independent views with minimal dependence on input from the NMT Consultants. However, most of the project reports were produced by the consultants, either directly or under their close supervision. A significant proportion of the reports were not made available to the assessment team. Important lessons have been learned on how to involve users at all stages of the project cycle, and building capacity in local authorities. This information will be of enormous benefit to governments, local authorities, planners and engineers throughout SSA.

²⁷ De Langen and Tembele, Op. cit.

²⁸ Scott Wilson, Op. cit. p. viii.

5 USER PARTICIPATION AND DECISION MAKING PROCESS²⁹

5.1 User Participation

User participation is a necessary pre-requisite to successful development projects, particularly in the field of non-motorized transport (pedestrian and bicycle mobility). Different user groups perceive problems differently. Their views and perceptions are important inputs in making an inventory of problems, prioritizing the interventions and identifying the most appropriate solutions. It is important to respect the opinions of all users, especially the urban poor and the vulnerable users, for what they can contribute towards the development. Furthermore, user participation and subsequent continued user involvement are essential to the sustainability (maintenance, renewal, monitoring and system use) of the investments made. User participation should be an integral part of all urban transport improvement.

5.2 Principles of User Participation

Basic Principles of user participation are to:

- A. Involve and respect the NMT users as experts who can bring into focus problems experienced in daily travel;
- B. Ensure that professionals, who are experts by training, make the appropriate choices to improve the mobility of NMT users;
- C. Assure that the process is transparent and explicit in terms of the articulation and prioritization of different interests, decision-making and project costs (leaving no room for hidden agendas or unnecessary suspicions); and
- D. Make sure that the users are the ones to determine implementation priorities.

5.3 Benefits of User Participation

User participation results in many benefits, the more important being:

- A. Optimism among the users that improvements are possible and pride of ownership of the improvements (especially important when users are also the contributors to project costs through labor or cash);

²⁹ This chapter is derived from SSATP Working Paper No. 71 and de Langen and Tembele, Op. cit. Chapters 17 and 18.

- B. Capacity building (of users) with respect to the identification of problems, balancing interests of various stakeholders in a transparent way and working out appropriate solutions;
- C. Sustainability of NMT interventions (maintenance and renewal);
- D. More transparent prioritization, designing and costing of interventions; and
- E. Increased monitoring of project finances.

5.4 Structure of User Participation

The Figure 5-1 below illustrates the structure adopted in the NMT pilot projects for user participation. Four levels were adapted:

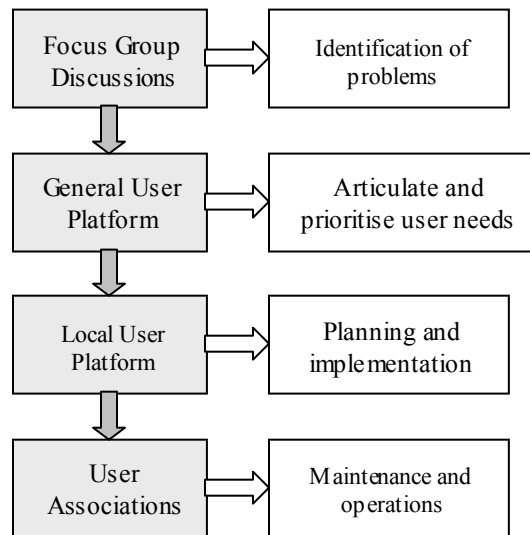

Figure 5-1. User participation structure³⁰

- A. Focus Group Discussions (FGD) with existing community-based organizations, user groups and key stakeholders in the project areas. The primary purpose of these discussions was to identify the basket of mobility problems with particular reference to NMT infrastructure or the lack of it. Subsequently, these groups were invited to form the General User Platform (GUP).
- B. The General User Platform (GUP), comprising representatives of the existing user groups and stakeholders in the entire area to identify, review, articulate and prioritize the problems identified by the FGDs.

³⁰ Scott Wilson, Op. cit., Figure 2, p. 32.

- C. Local User Platforms (LUP), comprising of NMT users in the immediate area of the proposed improvements, to take part in planning, designing, implementation and monitoring of specific local interventions.
- D. User Associations (UA), which are existing or emerging permanent organizations of users. They were expected to become responsible for the operation and maintenance of specific NMT infrastructure.

5.5 Focus Group Discussions

The best way to document the mobility problems of NMT users is by conducting FGDs with the people residing in the project areas. Although communities are best at defining their problems, they lack the means to solve them. Detailed household surveys, though very useful, are quite costly. In addition, people are busy with their lives and large meetings do not provide an avenue for every one to express their concerns. Furthermore, FGDs facilitate the contacting of specific groups as needed (women, local leaders, specific NMT users, specific age and income groups) and make it possible to cover a wide geographic area. They also allow for a careful selection of representative samples of people in the neighborhood.

FGDs covered the following aspects of the pilot projects:

- A. Inventory of views, problems, and interests related to mobility;
- B. Exploration on willingness of the groups to participate in a General User Platform (GUP) through one of its group members if asked to do so and through the GUP, sharing responsibility for the decision making in the project;
- C. Exploration on the willingness of the group to contribute (cash or labor) towards the cost of interventions and towards their maintenance.

The Focus Groups must be well defined and representative of all interested parties in order for the FGDs to be useful. The three main categories of NMT users are pedestrians, cyclists, and cart operators. Within these broad categories, other homogeneous sub-groups were formed (age, gender and place of residence, all living in the same neighborhood).

FGDs are not suitable instruments for gathering information about the actual travel behavior of individuals. It is not a substitute for a household travel survey, but complementary to it. It provides an overview of user mobility experience, points of view and ideas.

5.6 General User Platform (GUP) – Articulation of Prioritization of User Needs

The GUP members were selected carefully to avoid blatant biases and private agendas. The qualifications for membership were:

- A. Members should not represent political parties, be government officials or be professionally involved with the subject. To facilitate a compatible and efficient

working environment, each GUP should be composed of no more than 15 to 20 members.

- B. GUP members should live or have business in the project area.
- C. The GUP composition should be representative of the whole user group in the area (gender, age, income, social and occupational categories); and
- D. Members must be committed to solving the core problems and be willing to spend time on project activities.

The core tasks for the GUP were:

- A. To articulate important mobility and accessibility problems of the people, living or working in the project area;
- B. To prepare an inventory of important mobility and accessibility bottlenecks in the project area;
- C. To identify and document dangerous spots on the roads (traffic accident risks), informal walkways and cycling tracks in the project area, and by including the consideration of social safety risks (robbery, harassment);
- D. To articulate solutions after discussing the range of interventions which are available to improve the mobility and road safety, and list all ideas on ways to address these problems;
- E. To prioritize the proposed interventions; and
- F. To prepare a "User Needs Document".

The work assigned to the GUP included:

- A. Discussion of the mobility issues in open public meetings;
- B. Holding workshops with city councilors, elected sub-ward representatives, relevant municipal and national government departments and other interest groups;
- C. Inviting comments and preparing a general work plan for future interventions;
- D. Walking through the area to identify the on-site requirements; and
- E. Learning to read maps and gain knowledge on technical and planning issues with the help of planning and engineering professionals.

The GUP was responsible for guiding the whole process of the articulation and prioritization of user needs, through the preparation of the User Needs Document. In addition, it was expected to interact with and get support from the Ward Leaders, government officials elected by the people in the ward, while at the same time keeping its independent position.

The GUP was engaged not only to carry out the tasks stated above but also to monitor the project implementation and later its evaluation, based upon clearly understood indicators. The GUP was provided a terms of reference, defining its roles and responsibilities.

The challenges experienced in the implementation of GUP model were:

- A. *Heterogeneity of the community.* The “community” in Temeke, for example, is very diverse, with people from various parts of the country, different educational levels and urban histories. Some are used to cooperating with their clan members over a wide region, and therefore able to reach a degree of self-sufficiency while others are not. In large cities, most people tend to be concerned only with their own family members, who live with them in the same household or elsewhere. Only when there is a common problem and when mutual trust has developed, will people without family ties jointly work for a solution.
- B. *Historically set attitudes.* Many people have a strong feeling that ordinary citizens are powerless in improving pedestrian mobility, bicycle facilities, or road safety because these problems and their solutions have always been the responsibilities of the government (e.g. Dar es Salaam City Commission). This makes people reluctant to cooperate with other community members on matters such as the provision of NMT infrastructure.
- C. *Continuity may not come easy.* In Temeke, GUP members were interested up to the period of writing the needs inventory. After the prioritization of the interventions, it became apparent to several members that the priorities of their own neighborhoods might not be addressed soon enough, so they lost their interest in further participation.
- D. *Allowances.* User participation in development projects is often associated with paying allowances to participants (meeting, food, travel, and task allowances) to compensate for the time spent and sundry expenses incurred. Generally, this process lacks transparency and is time-consuming for administration. It influences the relationship between a “project” and the GUP. Good cooperation with user group and user platform members could come to depend mainly on the payment of allowances. When this happens, it becomes unclear what the important reason for their participation is: whether it is addressing the problems or receiving the allowances. This undermines the user participation.
- E. *Breaking away from the allowances.* The pilot project team in Temeke was keen to break away from the tradition of allowances and tried out other options. First, members of the GUP were paid a small salary at the end of the month as compensation for the time spent on project activities, according to their Terms of Reference. Even with this fixed salary, certain members attended the meetings very irregularly. Some attended, but did not come prepared to discuss

items and neither had consulted with their community in preparation. Often, they either did not contribute in the meetings or only gave standard opinions. The second change was that the PPU completely stopped paying UP members' salaries. The PPU observed that not paying allowances had a positive effect on user participation.

It is the task of planners and engineers to provide a range of possible traffic interventions. For example, when people complain about speeding cars and buses on a particular road, possible solutions to these problems could be the installation of a speed bump, a traffic island or a raised pedestrian zebra crossing. The discussion between the “users” and the “professionals” should be primarily on the most suitable choice of the intervention for a particular location. Concepts of transparency, shared responsibility and shared credit are of paramount importance. Otherwise, the GUP members will suspect that the process is a sham where their presence is for appearance sake only.

Informing the public and the users about the cost of road and traffic engineering interventions is not common yet in SSA. However, there are advantages to being open about costs. When the members of the GUP knew about the costs involved, they took more interest in the construction works going on. The discussion of the design drawings, bills of quantities and the costs, gives GUP the information needed to keep a watchful eye on the use of materials and funds.

5.7 Local User Platform – Planning and Implementation of Interventions

Local User Platforms consisted of members drawn from the immediately affected community representing NMT users (pedestrians, cyclists, cart operators and owners, parents with children, the elderly, people seeking market and job access). Facing the daily mobility and traffic safety problems or experiencing severe access problems to a market or health clinic, makes the area residents keen to take part in the preparation and implementation of practical improvements. The members took part in planning and designing the interventions in their area, and sometimes in mobilizing resources (primarily labor) for construction and or repairs.

In general, participation was voluntary and unpaid. Although allowances were paid initially to some groups, the practice was found to be inappropriate and eventually discontinued. Subsequently these Platforms became the Community Transport Committees (CTCs), which acted as advisory groups to the local authorities.

The advantages of the LUP are:

- A. The establishment of several LUPs instead of one GUP makes it operationally easier for the PPU;
- B. Different sets of users familiar with the problems develop solutions and the PPU coordinates the activities;

- C. Easier to reach consensus, the LUP being smaller and members having common interests;
- D. Easy to call meetings, to communicate, to share information and persuade each other because all members live in the same neighborhood; and
- E. Genuine commitment and no allowances required.

Implementation of the LUP model resulted in some interesting challenges. The PPU had to deal with several LUPs at the same time. Providing guidance to the LUPs concerned with a large number of interventions at different locations created an excessively high workload for the PPU and sometimes it became difficult for them to attend all the different LUP meetings. In addition, it was often difficult for them to complete all the required follow-up to government departments for approval and implementation of the interventions. However, this list of challenges is short and less formidable when compared to the list resulting from the GUP model.

5.8 Effectiveness of User Platforms (General and Local)

The GUPs and LUPs were disbanded after the implementation of the interventions and a short period of monitoring since their role was specifically to contribute to the NMT pilot project activities. In addition, they were closely linked to the PPU whose existence was tied to the lifetime of the NMT project.

The GUPs and the LUPs were effective in giving voice to the community. Participants were initially unable to contribute significantly to designs due to lack of technical experience, which improved significantly over time. They made a major contribution to public awareness campaigns.

The User Platforms contributed positively to the outcome of the pilot interventions. Their confidence, pride and level of contribution increased as they gained experience. New ideas and initiatives started to emerge from group activities. It is therefore unfortunate that they could not continue in a form (perhaps simply as a lobby group) that would enable ongoing input to the management and improvement of NMT infrastructure.

5.9 User Associations

User Associations (UAs), as permanent legal entities, are very useful with regard to proper user use and maintenance of already constructed NMT infrastructure. For example, these associations can safeguard the proper use and maintenance of the pedestrian-only access tracks in a specific residential neighborhood, or assure regular cleaning of the riverbed under an NMT bridge to prevent silt accumulation and thus damage to the bridge.

A UA can obtain a permanent legal status. Subsequently, it can obtain a license from the municipality to operate an infrastructure (NMT bridge) or a facility (park), or a long-term lease contract, with the lease fees paid to the municipality. This would generate income, which could be dedicated for the maintenance of the infrastructure.

One LUP graduated into an UA: the LUP, responsible for the upgrading of the Mwembe Ladu Park in Temeke, became the Mwembe Ladu Park User Association (MLPUA). Prior to that for almost two years, the PPU and the LUP cooperated to develop the park with great success. Throughout the second year, the activities of the LUP aimed at establishing an UA, which could protect the interests of the local users, make the park flourish and further improve it. It was thought that this would be the most appropriate way of assuring an efficient permanent operation and therefore sustainability. The underlying thought was that the local government would not look after the park properly and may not improve it further. Therefore, “privatizing” the operation and maintenance would be a better solution.

However, in the final analysis, and based on the direction in which the UA was developing, it was concluded that such facilities are better managed by the local authorities. Private operation, even by an UA, would probably lead to commercial exploitation, e.g. by renting fields to sports clubs, requiring fees from petty traders, renting advertisement space to commercial firms, allowing wedding celebrations for a fee, etc. However, this commercial exploitation of the park was contradictory to the original purpose of having the park freely open to the public (as a pedestrian path as well as resting spot in the shade).

5.10 Awareness Raising and Publicity

Awareness raising and general publicity on mobility problems and NMT issues can be useful for several reasons. These campaigns do not target users as individuals but as particular interest groups (high school students, car drivers, cyclists, etc.). Awareness raising activities should influence traffic behavior and make people more conscious of certain changes in the traffic situation, and therefore the new facilities should be used in a specified and appropriate way.

Whether awareness raising and publicity involves users as partners to improve things in practice, or it is “educating” the public to a particular point of view, without doing much on the ground, makes a big difference. People will begin to perceive mobility problems as something, which they themselves can influence, if they are partners in awareness campaigns.

Awareness raising programs must not only concentrate on focusing on the problems but also should focus on what one can do to improve things. The awareness, that users can make a difference, is crucial to the success of these programs. This type of awareness could result in the community realizing what their mobility needs are, how they can make improvements and what contribution they can make.

Experience in the NMT projects shows that safety is by far the most important aspect of mobility. Unfortunately, traffic accidents for NMT users are common in SSA and the impact of being in a traffic accident on the person, the family and the household is quite severe. Therefore, it is essential to ensure that the awareness campaigns include traffic safety.



Photos 5-1 and 5-2. Awareness campaign in Morogoro

Inclusion of awareness and publicity campaigns has several advantages:

- A. The general public becomes aware that traffic safety is an important issue to the municipal government, if it organizes traffic safety awareness activities in cooperation with groups of road users;
- B. This could increase the willingness of people to participate in efforts to improve the safety situation by means of local interventions;
- C. The community could accept traffic safety interventions in a positive way and use them as intended; and
- D. Generally, people are likely to pay more personal attention to safe traffic behavior.



Photo 5-3. Promotion campaign in Morogoro

Large-scale general awareness campaigns can be costly and have limited impact without follow-up. It is not easy to measure the effectiveness of these campaigns even if the reactions are friendly. Awareness campaigns without follow-up in terms of real activities have no lasting impact, or may even influence the attitudes in a negative manner. The best approach is targeted campaigns combined with real interventions.

More people are willing to take part in awareness and publicity activities if they perceive that their participation will make an impact. The most successful awareness raising activity, in the pilot project cities, was the traffic safety campaign and song competition in Temeke primary schools, aimed at the children.

The projects produced a NMT traffic safety video with the objective to motivate professionals and policy makers to address traffic safety by means of NMT-oriented interventions that would eventually ensure every road user's safety.

5.11 Making User Participation Effective

All groups who take part in user participation (NMT users, professionals and others) must share the expectation that each party can and will make a valuable contribution. All deliberations must be in the national language, not in a foreign language such as English. It is vital, to include all users and to assure a level playing field, without any language restrictions.

User participation is a matter of cooperation between users and professionals. The users contribute their knowledge and experience and sometimes resources (cash or labor). They can prepare lists of interventions based on their knowledge and experience. The challenge is to strike a balance between the two perspectives, those of the users and those of the professionals.

The traditional option is where the PPU decides entirely on its own, with the approval of the city engineer, submits the list of interventions to the city council for approval and considers the UP comments as advisory. Alternatively, the PPU can, without interference, leave the preparation of a priority list entirely to the GUP and in addition, let the GUP make the final choice of what is to be proposed to the council for approval.

The advantage of the first option is that the PPU has complete control over the outcome. The disadvantage is that the GUP may not be inclined to share the responsibility for their implementation. Moreover, the selection might not cover all spots or even address their real needs. In this case, however, it is also less probable that the GUP would want to play a role in either the implementation or the maintenance of the interventions since there would be no realistic "ownership" of the interventions.

The advantage of the second option is that it lays total responsibility for the choices with UP, so nobody can accuse the PPU of making the wrong choices. It is also possible to link the acceptance of user proposals to a user obligation (general or neighborhood population, or the business community) to contribute a substantial part of the cost (in cash or in kind). However, the primary disadvantage is that because of lack of contributory resources, a very limited range of interventions could be proposed (such as speed bumps and pedestrian bridges only). This would contradict the purpose of creating a balanced and integrated development of NMT facilities in the area. Furthermore, it could lead to a situation where the municipality would not as-

sume its own responsibility over infrastructure provision and thus lead to further deterioration of the available NMT infrastructure.

Communities are very heterogeneous. Such a thing as the average Temeke resident or Morogoro resident does not exist. Simple and good-for-all solutions are not easy to identify, because of the very different conditions. Professionals have to be cautious when working with such heterogeneous communities. The professionals have the technical expertise to choose the most suitable traffic improvements. They can provide input about what to do and how to do it. Together users, professionals and other stakeholders can better plan and implement, together they can share the credits when there is success, and together they can take the blame when there is a failure.

5.12 NMT Infrastructure Assessment

Professional Input

The NMT user participation process requires high quality professional work. The quality assurance of the proposed interventions, as well as their credibility to the highest decision makers in the municipality, requires that the UP members' judgments and priorities are supported and verified by neutral professional assessments. Particularly important is a professionally reliable overview of problem spots in a given neighborhood. The professionals and UP members must make a joint assessment to verify the problem spots indicated by the users and identify which traffic interventions might best solve the problem.

Articulated by the Users

The listing of NMT problem locations, emerging from focus group discussions and later prioritized by the GUP, must be balanced with the "NMT problems and infrastructure requirements assessment" prepared by the PPU. Priorities of NMT users and the observations of the professionals must be discussed and balanced. The outcome of these discussions can best be articulated in a separate report, this time written by the UP members, the "User Needs Document". This is a document that "belongs" to the UP members and the final responsibility for the document lies with the UP.

For further decision-making, the user needs document is the more important of the two. The NMT problems and infrastructure requirements assessment report is an input to it. This shows the important role given to the priorities as expressed by the GUP. However, the user needs document should not state priorities and interventions contradicting sound professional judgment. Serious differences should be reconciled before final reporting.

5.13 Traffic Calming in Temeke, an Example of UP

Shortly before the NMT pilot project started in Temeke, the National Ministry of Works had rehabilitated the pavements of a number of collector and arterial roads, including Temeke Street. This had improved the motorized traffic flow through the CBD, especially in the rainy season, (previously the area was sometimes difficult to reach by bus or car). Unfortunately, it became much more dangerous for pedestrians and cyclists to use or cross Temeke Street because of the high speed of many cars and buses caused many serious accidents. At the start of its activities in 1995, when the PPU contacted the residents of Temeke to conduct FGDs, many people had already expressed major concerns about this issue.

The GUP held discussions leading to the intervention proposals made by the PPU to construct raised pedestrian crossings, speed bumps and by redesigning some intersection corners. The GUP, in its first attempt, identified the following two priority interventions:

- A. Crossings and traffic calming on Temeke Street, to make it safer for pedestrians and cyclists, and
- B. NMT only bridges, on the Yombo River, to improve the NMT connection between the “Yombo Island” and Temeke CBD.

There were difficulties, however, in deciding on local priorities with a GUP consisting of people who lived all over Temeke. Naturally, people would be in favor of interventions close to their own house. When that did not happen, some of the members did not see any further reason to attend the GUP meetings and did not bother to make significant contributions towards interventions. In one of the meetings where the local priorities were discussed, some members categorically showed dissatisfaction over the priority list.

The PPU made intervention designs and shared them with the UP. The intervention designs were then submitted to the Dar es Salaam City Commission (DCC) for approval. The DCC approved the interventions as part of their commitment to carry out this NMT pilot project, which consisted of five raised zebra crossings, two speed bumps on Mahunda Street and street corner realignments.

During the implementation, the political situation in the ward was tense, due to a by-election for a parliamentary seat, in which the opposition candidate, who lost the presidential elections the year before, stood as a candidate. The test realignment had been very effective in reducing the motor vehicle speeds and demonstrating pedestrian safety had priority. However, these interventions had been carried out experimentally with removable oil drums filled with concrete. The political leaders considered them controversial and untidy. This led to instructions to remove the realignment of two intersection corners.

Immediately after the raised crossings were constructed in July 1996, there was a wave of protests to the Temeke Zonal Director and the District Commissioner, by motor vehicle drivers,

demanding that these interventions (obstacles) be removed immediately. This time the leadership reacted in a quiet manner and meetings were called involving the PPU and the user platforms to discuss the issue. UP members strongly defended their priorities and wanted the Dar es Salaam City Council (DCC) to acknowledge the importance of having these facilities for the pedestrians. In response, the DCC decided not to give in to the motorized drivers' protests and leave the crossings in place. However, as a compromise the slopes on two spots were made a little less steep to make it easier on the motor vehicles but without reducing the effectiveness of the speed reduction.

After the construction of the first raised zebra crossings on Temeke Street and after the first bus bays turned out to be a success, two other bus bays were improved. Buses were prohibited from stopping on the road shoulders and this finally produced a much more disciplined and efficient traffic pattern, both for NMT and motor vehicles. Users reacted positively.

The PPU then tested a different technical design of a raised zebra crossing on Mbagala Street, 500 meters beyond the end of Temeke Street. Since the testing was mainly concerned with finding the best construction method, the engineers first thought of doing their test without involving the people affected by the interventions. They wanted to do the test quickly and assumed that they were now familiar with the user's needs, only to find out that they made a mistake. They should have discussed this in depth with the LUP first, in order to identify the best precise for this location. User participation has to be a permanent part of the decision-making process to guarantee that the right priorities are determined and the best intervention choices made.

6 NMT PILOT PROJECTS³¹

6.1 Background

The SSATP conducted a major study in 1990 to examine policies, regulations, and management of the public transport sector in twelve cities of SSA. It provided the basis for a strategy paper for the "SSATP Urban Mobility Component".³² The first phase of the program centered on a series of comparative studies on the evolution of urban transport in twelve cities during the 1980s. These studies dealt with the institutional, economic, technical and regulatory environment underlying the widespread deterioration of urban mobility throughout the decade. The findings of these studies were discussed during a regional seminar in Yaoundé, in March 1991. The identification of the main causes of the deterioration in urban mobility provided the basis for designing a sector strategy.³³

The second phase commenced in 1992. A study to analyze NMT development issues in Mali, Burkina Faso, Senegal, Tanzania, and Kenya, was undertaken in 1993. Further to this study, the SSATP decided to implement a program of pilot NMT infrastructure improvements in Kenya (Nairobi and Eldoret) and Tanzania (Temeke ward of Dar es Salaam and Morogoro). During 1995 to 1999, this program was implemented, with financial contributions from the Netherlands Ministry of Foreign Affairs.

6.2 Objectives of the Pilot Projects

The long-term objective of the NMT pilot projects was to facilitate capacity building at the local government level in SSA cities, to design and implement affordable urban mobility policies, in particular non-motorized transport policies targeted to benefit the urban poor.³⁴ The pilot projects were to contribute to the achievement of this objective through the practical testing of NMT measures and policies, institutional development and capacity building in local authorities and the training of professional staff. The primary objective of the pilot projects was to explore those instruments, which could enhance efficient walking and cycling in the pilot project cities. Several interventions were implemented and their performance monitored.

³¹ This chapter is derived from SSATP Working Papers No. 3, No. 35, No. 69 and No. 71, de Langen and Tembele, Op. cit. and World Bank project files.

³² Urban Transport Working Group, Strategy Paper for UNTACDA II, Economic Commission for Africa, Addis Ababa, December 1990.

³³ Patrick Bultynck, Urban Transport 1998-2002 Strategic Development Plan, SSATP Working Paper No. 35, 1998.

³⁴ SSATP Urban Transport Component: Non-Motorized Transport, Terms of Reference Phase II, January 1995.

In most SSA cities, about half of the trips are pedestrian trips, with pedestrians and cyclists being the most affected by the growing number of traffic accidents. Therefore, the lessons learned, from the NMT Program in Kenya and Tanzania, could be valuable tools for improving the mobility of those who are the most affected by the absence of appropriate NMT transport infrastructure.

Phase I of the Pilot Project Program (PPP) was implemented during 1995-1996. Its efforts focused on:

- A. The establishment of Pilot Project Units (PPUs), responsible for the implementation of the Pilot Projects and for the development of the local capacity for planning and designing of NMT infrastructure facilities and services, within each municipality in the four cities;
- B. Consultations with users of non-motorized transport; selection of an initial battery of interventions or tests;
- C. The selection and design of an initial battery of NMT interventions; and
- D. The implementation of the selected interventions.

Phase II of the PPP was implemented during 1996-1999. Its goals were to:

- A. Train municipal staff in institutional matters pertaining to NMT;
- B. Organize systematic consultations with stakeholders and users;
- C. Initiate awareness campaigns on the safety of pedestrians and cyclists,
- D. Develop urban mobility plans;
- E. Design test interventions in the area of traffic management and NMT infrastructure facilities; and
- F. Propose affordable financing schemes for the ownership (purchase) of bicycles and suggest measures to increase the use of bicycles.

6.3 Selection of Pilot Project Cities

Four cities (two major cities and two secondary towns) were chosen for the pilot projects: Te-meke municipality in Dar es Salaam and Morogoro (Tanzania), Nairobi and Eldoret (Kenya). Nairobi and Dar es Salaam are two major national capitals, Eldoret and Morogoro are two medium-sized cities. The rationale for choosing the capital cities of the two countries was that if the project succeeded in these cities, then it would have a demonstrable effect on other SSA cities. In addition, a vast majority of the people living in the capital cities are unemployed and cannot afford motorized public transport services. They are exclusively dependent on NMT. Another reason for this choice was to enable the comparison between two large cities (Dar es Salaam and Nairobi) and two medium-sized cities (Eldoret and Morogoro), which have different levels of cycling. Cycling was an insignificant transport mode in Dar es Salaam (3 percent of

daily trips) and Nairobi (1 percent). However, cycling accounted for 23 percent of all daily trips in Morogoro (more than buses and private cars put together) and 12 percent in Eldoret.

In order to be selected, the two medium-sized cities (Eldoret and Morogoro) had to fulfill the following conditions:³⁵

- A. To demonstrate a history of good governance including sound financial management;
- B. To be smaller than the capital city with an urban-rural character and depict the transport patterns typical of secondary towns (In Morogoro, 80 percent of all trips are by NMT and only 20 percent by MT); and
- C. To be small enough in geographic area covered, because of the constraints of time and money.

The choice of sites, to be treated, used the following consultative process:

- A. Baseline surveys indicating the main problems areas and challenges which would culminate in workshops,
- B. General User Platforms to help prioritize the sites and the related interventions, and
- C. Local User Platforms to help select the type of intervention, choose the design and guide the process of implementation.

6.4 Mobility Planning

Two primary objectives of mobility planning in the pilot project cities were to: (a) increase the mobility of the households and (b) reduce the total cost of making these trips. A substantial majority of the people, particularly the poor, walks for all their daily trips. However, in almost all of the SSA cities, walking and cycling are inefficient, unsafe and costly (both in direct and indirect costs). Household transport costs are high and generally, travel on urban roads is unsafe. However, the situation is even worse for the urban poor who are the primary NMT dependent.

The poor are poor because they “have not enough money for their daily needs”. However, urban transport inefficiencies, particularly for the NMT users and NMT dependents, further exacerbates their condition of poverty by making it more difficult for them to seek and keep employment, to access markets and other socio-economic opportunities and for personal needs. Fundamentally, any policies to increase the mobility of the urban poor mandate that urban transport planners provide for economically efficient (direct cost and time costs), socially re-

³⁵ M. Omwenga et al, Preliminary Assessment of NMT Potential in Eldoret, Report No.15, December 1994.

sponsive (access to social infrastructure) and safe (reduction of the potential for traffic accidents) infrastructure for the NMT users.

The populations in most cities of SSA have low incomes. Furthermore, they are saddled with urban transport systems, which have been primarily designed for high-income cities. These urban transport system designs assume that motorized traffic should be the backbone of urban travel. In addition, public transport is generally too costly for the majority of the people. Under these circumstances, any increase in urban mobility would be achieved, by improving the efficiency and safety of NMT, which would enable the lower income populations to increase the ownership and use of bicycles, and produce perceptions of safe NMT travel.

The pilot projects introduced mobility planning techniques to local authorities in Nairobi, Eldoret, Dar es Salaam and Morogoro. They sought to improve mobility and accessibility at a lower overall cost and to meet the needs of all residents, rather than only those of the motorists. Two components of mobility planning were identified:

- A. The preparation of urban mobility plans for pedestrians and bicycles, and
- B. The provision of spot improvements to non-motorized transport infrastructure in accordance with an overall urban mobility plan.

Mobility planning included the following:

- A. The preparation of urban mobility plans for pedestrians, bicycles and other forms of non-motorized transport
- B. The provision of non-motorized transport infrastructure in accordance with an overall urban mobility plan, and
- C. The modification to motorized transport infrastructure to accommodate the needs of NMT.

The preparation of mobility plans is a complex process that requires significant inputs from external consultants in most SSA cities. However, the provision of spot improvements to motorized and non-motorized transport infrastructure within the context of the mobility plan requires relatively little technical know-how. It is possible to achieve significant mobility improvements, with modestly few resources.

6.5 Mobility Planning Menus³⁶

Three distinct menus were used in the pilot projects:

- A. Build special infrastructure for pedestrians and cyclists;

³⁶ Scott Wilson, Op. cit.

- B. Introduce traffic calming measures to reduce speed and thus increasing safety for NMT users; and
- C. Include interventions to increase the ownership and use of bicycles.

Adequate road infrastructure which provides appropriate road space safe for efficient pedestrian and bicycle trips will enable the lower income people to make more trips safely and efficiently (total cost), within the time they have available and thus enhance their mobility. The problem is not complex and the intended solutions can be simple. The pilot projects focused on improvements to the more problematic locations on existing roads. The two menus for improving the NMT infrastructure and traffic calming were inter-related and when applied on a large scale, they could produce considerable improvements in mobility and safety.

6.6 Improving Pedestrian and Bicycle Infrastructure Facilities

Table 6-1 below shows the menu for improving NMT infrastructure facilities, which was adopted for the pilot projects. These are simple, easy to comprehend, and low cost improvements, which are likely to result in immediate improvements to the mobility of NMT users.

Table 6-1. Menu for improving NMT infrastructure³⁷

Category and type of intervention
1. Walkways: separation from motor transport, dedicated to walking, preventing motor vehicle interference, paved without obstructions, safe crossings.
2. Construction of missing cycling and walking links, including NMT bridges
3. Safe and convenient pedestrian crossings: raised and painted zebra crossings, islands for pedestrians and cyclists,
4. Dedicated bicycle tracks (lanes): in cities with significant cycling
5. Appropriate intersection designs: to increase the efficient traffic flow of NMT

Walkways

Table 6-2 shows the walking speeds measured in Temeke in 1998/1999, after the implementation of the interventions. It shows that walking efficiency was adversely affected incrementally by bad pavement quality, location and volume and obstructions (garbage, parked vehicles, pot-holes and broken pavements) forcing detours, resulting in the waste of valuable time.

³⁷ De Langen and Tembele, Op. cit., Tables 3.2 and 11.1

Walking and Cycling: Missing Links including NMT Bridges

The directness of a route has a strong impact on trip time. In Morogoro, Eldoret and in the unplanned areas of Temeke, pedestrians and cyclists had to take significant detours mostly due to the absence of NMT crossings over small rivers and other barriers. In Nairobi and Dar es Salaam, large fenced plots or fenced neighborhoods also created significant detours. Construction of all-weather small NMT bridges (shortcuts) ranked very high in all user priority lists for improving accessibility. They were used intensively and very much appreciated.

Table 6-2. Walking speeds in Temeke (1998/99) ³⁸

Infrastructure Quality	Walking Speed, Km/hour		
	Average	Normal	Maximum
1. Bi-directional concrete slab walkway, un-congested	4.6	5.0	5.3
2. Bi-directional bitumen paved walkway, congested	3.5	n/a	4.0
3. One side only bitumen paved walkway on a collector road	3.5	n/a	4.0
4. Bi-directional cement stabilized way, un-congested	4.6	n/a	5.2
5. Unpaved and well compacted walkway, one side only on a collector road	4.5	4.9	5.1
6. Unpaved, not well compacted, straight and dry walkway	4.1	4.4	4.7

Safe and Convenient Pedestrian Crossings

On most streets of African cities, the pedestrians outnumber the people in vehicles (buses and cars). Efficient and safe crossing for pedestrians is of vital importance given the sheer number of people walking and having to cross the busy roads throughout the city. Usually, the pedestrians cross roads anywhere, rather than at dedicated crossing points.

To enable pedestrians to cross safely, the speed of the motor vehicles must be moderate at the crossing points. Very few drivers slow down or stop to allow pedestrians to cross. In order to enable safe crossing, it is necessary to reduce speed by introducing traffic calming measures. Safe pedestrian crossing and traffic calming are inter-related and traffic calming measures can achieve speed reduction at crossing points. The spots, where a vehicle travels at less than 30 kilometers per hour, provide reasonably safe crossing points for pedestrians.

³⁸ De Langen and Tembele, Op. cit., Box 12.1

An easy to recognize and effective pedestrian crossing as well as a speed reduction intervention is a raised zebra crossing. Slopes and width can be adapted to achieve the desired results with respect to speed reduction and pedestrian capacity at the crossing point. Raised zebra crossings are particularly useful at bus bays.

In general, drivers perceive the speed bumps as pure speed reduction measures. Speed bumps are also the least cost method of speed reduction. They make for safer road crossings. It is also important to assure that the speed of a motor vehicle does not increase excessively over long road sections.

A pedestrian crossing island can effectively facilitate road crossing. In single lane traffic, a pedestrian island reduces the crossing distance to 3.0 meters, and allows easy and safe crossing. The islands must be designed to prevent vehicles from driving over them. Pedestrian crossing islands also have a small speed calming effect, depending on the deflection of the carriageway. These measures increase pedestrian convenience and safety.

Dedicated Bicycle Lanes

The primary requisite for cycling in African cities is that traffic must be safe enough for cycling. Where vehicle speeds reach 60 to 80 km/hr in mixed traffic, cycling is dangerous. Special dedicated cycle tracks are of secondary importance since it is not possible to eliminate all the accident hazards, by merely providing separated cycle tracks. The cyclists still have to cross at intersections and without the reduction of speed, all the crossing points remain dangerous.

Drivers do not cause accidents on purpose. The most dangerous situations for cyclists arise if the motor vehicle drivers do not see them or only see them when it is almost too late to avoid an accident or if the cyclist does not see the vehicle soon enough to avoid being hit. Therefore, to make widespread urban cycling possible, the cyclists must be highly visible as part of the traffic flow.

There are two reasons for providing dedicated cycle tracks: lack of road capacity and the high speed of motor vehicles. The lane separation options are:

- A. A bicycle lane as part of a carriageway shared with motor vehicles;
- B. A mixed traffic service road parallel to a transit carriageway;
- C. A separate bicycle-only track; and
- D. A separate NMT-only track (bicycles and pedestrians).

When road capacity is a problem, separate bicycle lanes should be the first preference because they allow for flexible road use and simpler intersection designs. It is essential, in such a case, to limit the maximum speed to less than 50 km/hr. Another method is "Road narrowing with bicycle slips" to enhance better motor vehicle and bicycle lane discipline on a mixed carriageway. In addition, where congestion starts to build up on urban roads, creating enough space for cyclists at the intersections is very important. The use of wide crossing islands (medians),

which create protected spots for the cyclists at the center of the intersection are probably the best solution.

When the reason for separating the bicycle from motorized traffic is the speed of the motor vehicles, a dedicated cycle lane is not necessarily the best solution. The solution can be a mixed traffic service road, an NMT only track (mixed pedestrian/cycle/cart), or a bicycle-only track. In case of separation, careful design of crossing points at the intersections is crucial. If those points are not safe and efficient, the value of a separated cycle track will diminish substantially.

The overall capacity requirements become important in a mixed pedestrian/cycle track. This design is usually chosen when the separation of a cycling route from a high-speed corridor occurs through the selection of a completely separate alignment for the bicycle route, partly consisting of route sections without motor vehicle access. Pedestrians can also use such routes, which will quite often be attractive shortcuts for them. It is thus desirable to assure that the track capacity is sufficient for both pedestrians and cyclists. The opportunity to cycle along the major urban corridors is essential as it enables cycling throughout an entire city.

If a bicycle-only track is chosen, the bicycle volume should be large enough to protect it from being invaded by other users (street traders, pedestrians or parking vehicles). In Morogoro where cycling was the second dominant mode choice, the road rehabilitation plan included separated cycle-only tracks for an important corridor, combined with sufficient parallel walkway capacity with motor vehicle access to low density plots along the road via side roads only.

In the pilot projects, experimental evidence was limited to tests with two short sections of new separated bicycle tracks in Eldoret and observation of the usage of the old existing cycle tracks in Dar es Salaam. The findings indicated that segments of separated bicycle track along roads in the central part of a city, with an equally urgent shortage of pedestrian walking space, could be largely be taken over by the pedestrians and that sufficient traffic calming should be adopted.

6.7 Traffic Calming on Existing Streets

Table 6-3 shows the menu for traffic calming on existing roads, tested in the pilot project cities.

Raised Zebra Crossings and Speed Bumps

The most effective and inexpensive traffic calming option is a speed bump. However, speed bumps also have a number of disadvantages. The test interventions indicated that the best speed bump was the one with a sloping top, constructed with pre-cast concrete blocks and a short flat top where the approaches are built with a strengthened foundation and a brick pavement. The initial investment, in this type of bump, is approximately 50 percent higher than that of an asphalt bump. However, the total annual costs are less when maintenance costs are included. In fact, this design is almost identical to that of a raised zebra crossing. At all loca-

tions where there was a significant volume of pedestrian crossings (bus bay locations, intersection corners, or an NMT route crossing at a mid-section point), a 4 meter-wide raised zebra crossing, was implemented.

An alternative, to either speed bumps or raised zebra crossings at intersections, is to raise the entire intersection. This option was not tested in the interventions. The common speed bump problems requiring attention were:

- Potholes in the bitumen pavement near the bump, generally caused by insufficient foundation bearing capacity.
- Irregular shaped asphalt concrete bumps deformed easily over time. A better alternative appeared to be the bumps of pre-cast concrete blocks with standard shape, good strength and durability.

The visibility of the speed bumps was generally insufficient. Road signs do not improve visibility in this situation much. One-meter high steel bollards, painted reflective black and white, appeared to be the best option. In addition, concrete block bumps have a lighter color than asphalt, and are therefore more visible.

Flat top bumps create less vehicle damage problems compared to round-top ones. If the driver reduces the vehicle speed properly, they cause neither vehicle damage nor any riding discomfort. Indiscriminate use of bumps and failure to differentiate height and slope in line with the road hierarchy, make vehicle drivers lose their sense of road hierarchy. Good road hierarchy is an important instrument to increase the traffic flow capacity.

Table 6-3. Menu for traffic calming³⁹

Type of Intervention
1. Raised zebra crossing
2. Speed Bumps
3. Intersection corner designs: Reconstruction and geometric design changes
4. Hard separation between carriageway and road shoulder
5. Pedestrian and cyclists crossing islands
6. Medians
7. Narrowing Bicycle slips
8. Pavement repairs, new pavements and raising platforms.
9, Medians
10. Low speed roundabouts
11. Bus bays combined with raised zebra crossing

³⁹De Langen and Tembele, Op cit., Chapter 12.3

Re-design of Intersections

Historically, many of the existing intersections in African cities were designed according to rural highway standards. As a result, they are wide and allow high vehicle speed. Wide intersection corners create a number of significant problems:

- Accident hazards as a result of high vehicle speed at a spot where low speed is required to achieve safety;
- Significantly increased carriageway width and thus increased crossing distance and waiting times for pedestrians and cyclists; and
- Illegal use of the intersection corners as waiting areas for taxis, parking, carts and mini-buses.

For the above intersections, reconstruction with a smaller corner radius is an effective traffic calming measure. It reduces the vehicle speed, without causing discomfort, thus significantly increases safety. Pedestrian crossing also becomes easier, since there is less crossing distance. The recommended design radius is one that is just enough to accommodate the design vehicle (the largest allowed vehicle to pass at 15 km/hr).

Many existing roads in SSA cities do not intersect at 90 degrees. They often have only three approach roads. If it is a Y-junction at a smaller angle, the vehicles could be turning the junction at higher speed than safety requirements. Reconstruction of Y-junctions into rectangular T-junctions is an effective traffic calming measure, which also increases traffic safety.

Carriage Way and Road Shoulder Separation

Open road shoulders, along urban roads, greatly increase the traffic accident hazards. They create undefined areas along the edge of the carriageway, which are used for a range of conflicting purposes: walking, parking, picking up and dropping bus passengers and freight, street trading, and overtaking maneuvers. Construction of a physical separation between the carriageway and the shoulder largely eliminates many of these conflicts. The use of triangular concrete “T-blocks” is an effective and inexpensive solution. They command respect from drivers and make the vehicles remain on the carriageway. In comparison, vehicles can easily damage the bollards.

The locations where it is important to create an un-mountable physical separation between the carriageway and the road shoulders (pedestrian space) are: intersection corners, bus bays, 25 meters on both sides of raised zebra crossings, speed bumps and crossing islands. Where possible, it is important to separate the carriageway from the road shoulders along the straight sections, to secure a safe walkway.

Medians

On narrow urban roads, overtaking another vehicle by using the contra-flow lane renders the traffic situation more dangerous. When the traffic volumes are almost at saturation, overtaking further reduces road capacity. An effective traffic calming measure on two lane roads is to construct a continuous median between the opposing flows. This would result in:

The elimination of overtaking, for a quieter traffic pattern,

The elimination of excessive speeds by constraining vehicles to drive at normal speed, and

Enabling of dispersed pedestrian crossings along the road sections (it must be wide enough, \geq 1.0 m, and protected by a curb).

A median on a dual carriageway road (2x2 lanes or more) is essential for safe pedestrian crossing. Without a safe waiting point in the median, crossing a 2x2 lane road is unsafe for pedestrians and cyclists, unless there is a traffic light with a pedestrian phase. The carriageway on each side of the median must be wide enough for vehicles to pass broken-down vehicles or pushcarts. The recommended design was a 4.5-meter carriageway, divided into a 3.0 motor vehicle lane and a 1.5-meter bicycle lane with no parking on the carriageway.

Road Narrowing with Bicycle Slips

Narrow carriageway sections have a speed reducing effect because vehicles, moving in opposite directions, cannot drive simultaneously through a narrow section at high speeds without the risk of a collision. It allows only two vehicles simultaneously at low speeds of around 20 km/hr. The bicycle slips are 1.0-1.5-meter wide side gates for bicycles, on either side of the middle gate for motor vehicles, separated by traffic islands.

On mixed traffic roads with wide lanes and significant bicycle volumes, narrowing of the road with bicycle slips achieves two goals:

- The speed of vehicles is reduced, making the road safer for cyclists, and
- The vehicles are channeled towards the center and the cyclists towards the side of the road, decreasing the friction between the two modes and therefore, increasing road capacity.

Bus Bays

In the pilot project cities, public transport essentially means "minibuses". Since minibuses are demand responsive, they stop often to load and unload passengers and thus adversely influence traffic flow and traffic safety. They stop at any location and at any time, as long as there is passenger demand, even when there are designated areas especially designed for them at terminal

points. Hence, the more chaotic the stopping behavior, the more negative is the impact on safety and traffic flow efficiency. Therefore, the provision of large enough bus bays at frequent intervals, which would minimize the number of minibus pick up points in busy areas, was considered an important infrastructure to facilitate efficient NMT flows.

Minibus operators initially opposed these traffic-calming measures, assuming that they would restrict their freedom to serve passengers and earn a living. However, the acceptance of these measures by the owners and drivers is important to successful consensus building and traffic calming. The PPU's conducted extensive consultations through the GUPs and LUPs in order to arrive at a consensus.

Bus bays can be positive instruments, which can specifically enhance the efficiency of operators and passengers. However, it is important that they are located appropriately, are of appropriate dimensions commensurate with public transport volumes, combined with the necessary pedestrian crossing facilities to ensure efficiency and safety.

6.8 NMT Infrastructure Improvements in Nairobi

Although an impressive and ambitious list of interventions was proposed for Nairobi, only a limited number of test interventions were implemented. Nairobi refused to implement most of the interventions proposed by the International Consultants because they considered these proposals disruptive to the already congested traffic flow (See Chapter 4 for a more detailed discussion).

Jogoo Road Interventions

In Nairobi, the engineering department refused traffic calming on Jogoo road, despite the fact that about 30 fatalities (pedestrians and cyclists) per year occur along this 5 kilometers long urban corridor, and despite earlier tests with painted zebra crossings that showed that these were completely ineffective in reducing the number of accidents.

The proposals, for more significant interventions on Jogoo Road, were rejected by the City Engineer. The reasons given for rejecting the proposals were that the proposed designs would narrow the road and introduce pedestrian crossings. It was felt that this would aggravate traffic problems, increasing the risk of conflicts rather than resolving them. The City's favored solution, to reduce conflicts along the road, was to construct pedestrian bridges. This view was opposed by the NMT Consultants, who pointed at local and international evidence that pedestrian overpasses tend to be "white elephants". This is now borne out by the poor performance of two pedestrian bridges constructed across Jogoo Road subsequent to the NMT activities and no reduction in accident numbers following their construction.

The only interventions carried out on Jogoo road aimed at (1) improving safety by reducing the tendency of NMT traffic to cross at any location on a road section, particularly the busy ones, and (2) testing whether painted-only zebra crossings would result in less accidents, motor vehicle drivers showing more respect for pedestrians crossing at these points. The interventions consisted of:

- A. Paving the pedestrian waiting areas at busy crossing points,
- B. Demarcation of the waiting area with steel bollards,
- C. Paved areas in the central median of the road including crossing slabs over the drains,
- D. Painted zebra crossings on the carriageway,
- E. Road signs, warning of the zebra crossings ahead, and
- F. Guardrails placed at a roundabout to channel pedestrians towards the crossing point.

The finding with respect to the effect of the interventions on a reduction in traffic accidents showed their inefficiency; no reduction in accidents occurred, and no change in traffic behavior of drivers towards pedestrians at the crossing points was observed.

In 2002, the paved pedestrian waiting areas were still in good condition. However, in many areas, hawkers had taken over the paved space to display and sell their wares. This has significantly undermined the usefulness of the paved areas for pedestrians.

Concrete filled steel bollards were employed to discourage motor vehicles from interfering with NMT infrastructure at road crossings. Bollards are generally considered vandal-proof. When hit by vehicles they might tilt but remain in the original position. They require low maintenance. Unfortunately, most of those hit by the motorists on Jogoo Road have not been repaired.

Painted-only zebra crossings, turned out to have no effect of reducing accidents: Drivers did not respect them in any way. In fact the accident hazards increased for pedestrians, as the painted crossings suggested fake safety. The tests had been carried out using weak paint, which faded after a couple of months and was not maintained, to get rid of the fake safety effect. Also, when the road was later resealed, the zebra crossings were not re-painted. Painted-only zebra crossings could only be effective in a situation where pedestrians have priority over motor vehicles at the crossing point, and this is forcefully and continuously enforced. However, in the existing traffic and traffic police situation, this is not feasible.

Nile Road Interventions (Details in Chapter 8.8)

Speed bumps and signage were implemented on Nile Road where there are two schools. These interventions were quite successful as speeds had reduced considerably and by 2002, there was a significantly improved safety. The speed bumps and the approaches are unlikely to require maintenance during their design life, the drainage system functioning quite well.

The decision-makers in Nairobi had argued that conventional painted zebra crossings would alert drivers who, in turn, would respect pedestrians and drive carefully. However, this was not the case. The provision of painted-only zebra crossings in Nairobi showed the lowest cost/benefit ratio of all pilot interventions. Table 6-4 below indicates the estimated benefit/cost ratios of the interventions in Nairobi.

Table 6-4. Benefit/cost ratio for NMT interventions in Nairobi⁴⁰

Intervention	Location	Total Number	Total Cost USD	B/C Ratio
Painted zebra crossing without speed calming	Jogoo Road	10 (10 m wide)	32,000	0.0
Speed bump	Nile Road	5	2,400	2.2

6.9 NMT Infrastructure Improvements in Eldoret (Details in Chapters 8.6, 8.11, 8.12, 8.15 and 8.16)

Test interventions implemented in Eldoret were:



Photo 6-1. Eldoret NMT separation

- A. Uganda Road works including parking rearrangement, pedestrian crossings and NMT tracks;
- B. Kisumu road layout realignment for traffic calming; and
- C. NMT only route crossing the Sosiani River, new low concrete bridge and new steel footbridge.

Uganda Road Interventions

Solid concrete blocks were built on the road surface to create a physical barrier between motor vehicles and NMT. They discouraged the former from parking on the cycle path. This was successful through municipality's development controls (forbidding the hawkers on pavements) through enforcement. Pedestrians could walk freely on the sidewalk and cyclists could use the newly created path. The concrete blocks were largely maintenance free and vandal proof.

⁴⁰ Scott Wilson, Op. Cit., p. 23, Table 3.



Photo 6-2. NMT Separation on Kisumu Road in Eldoret



Photo 6-3. Eldoret bicycle and cart slipway

Concrete filled steel bollards were used to discourage vehicles from interfering with NMT infrastructure on road sections, at junctions and at crossings. Subsequently, some bollards were damaged and were not repaired.

Kisumu Road Interventions

Guardrails were made from cylindrical hollow pipes welded together and anchored into the ground. These were prone to vandalism as they find a ready market in the informal metalwork businesses. In addition, the impact from motor vehicles can damage them. The performance of guardrails is dependent upon the education and sensitization of road users and the public awareness about their importance and use.

Open pre-cast concrete drains (concrete lined with rectangular side slabs) were constructed on Kisumu road on the approach to the Sosiani river bridge from the airport. The effectiveness of an open drain mainly depends on the surrounding soils and the base on which the drain is laid. In 2002, the drains were not performing well due to erosion and silting.

Pre-cast concrete curbs were laid along sections of the road, to prevent road and sidewalk pavement materials from dispersing. They also provided a channel for drainage as well as making it difficult for the vehicles to encroach from the road. While curbs are easy to maintain (by manually knocking off the damaged section at the cement/sand mortar joint), the damaged curbs have not been repaired.

From the Central Business District towards the Kisumu Road Bridge, the interventions such as bumps, raised zebra crossings and central islands, were performing well. However, beyond the bridge on the road to the airport, a speed bump was damaged and pushed out of position, by heavy vehicles. Pre-cast concrete curbs and bollards installed to discourage drivers from parking on the pedestrian path were not fully effective. Furthermore, the open drains, constructed as part of the project, were full of silt.

Sosiani River NMT Bridge (Details in Chapter 8.6)

On the Sosiani Bridge, the guardrails were vandalized to make way for NMT traffic seeking to cross at that point. The capacity of the footbridge was found to be insufficient and its access tortuous. In addition, loaded NMT modes found it difficult to use the existing bridge. Sosiani pedestrian bridge is used by pedestrians and cyclists and to some extent by the narrow gauge hand-pulled carts. Save for hawkers who took positions along the bridge to display their wares, the bridge was performing well. There is one redeeming factor, the vendors keep the bridge tidy.

6.10 NMT Infrastructure Improvements in Temeke

Temeke road had significant traffic problems:

- A. Significant speed difference between motor vehicles and NMT,
- B. Chaotic traffic conditions (stopping, parking of motor vehicles, etc.) resulting from the absence of physical separation between the carriageway and the shoulders, and
- C. Poor driver behavior, causing serious safety problems.



Photo 6-4. Sosiani bridge, Eldoret

In order to protect NMT efficiency and safety, a combination of traffic segregation and speed calming interventions were implemented. The interventions were also meant to discourage vehicles from parking on NMT infrastructure. Because Temeke Road had a road reserve of more than three meters, physical segregation between the two modes was provided by bollards, pre-cast concrete curbs and blocks.

Temeke road interventions (details in Chapters 8.4, 8.7, 8.9, 8.11 and 8.13)

One of the challenges on Temeke Road was dealing with sand, which had accumulated on the road reserve, pushed off by vehicles. Pedestrians, pushcarts and cyclists had difficulty traversing this sand and therefore tended to move back to using the carriageway.

Non-mountable pre-cast concrete curbs were laid along sections of the road. Those subsequently damaged, had not been repaired. In addition, where they had been employed in conjunction with an island to reduce speeds, they were not successful, the carriageway being not sufficiently narrow enough to force vehicles to reduce speed significantly. However, without adequate traffic discipline, street lighting and proper signage, further narrowing could have led to increased accidents, thereby defeating the original objective. The design used in the interventions, therefore, appeared to be a compromise between the two extremes.

The raised zebra crossings constructed on Temeke Road were effective as crossing points for pedestrians. Unfortunately, they had also become on-off passenger off zones for dala dalas. The development of potholes on the approach to crossings was a problem that required attention. The other issue, which required further research, was the criteria for locating the raised zebra crossings because they were not all well used by pedestrians.

Yombo River (Ward 14) Pedestrian Bridge (Details in Chapters 7 and 8.5)

A pedestrian bridge was built in Ward 14 as a result of user group recommendations. However, part of the bridge had been washed out due to lack of maintenance and shallow foundations. Debris trapped against the bridge and blocking the river channel caused the river to undermine the foundations and part of the bridge was washed away. A timber log has now been placed across the resulting gap and the bridge is largely functional for pedestrian traffic. People in Ward 14 used to walk long distances to access socio-economic activities on the other side of the river. This distance is now half the distance it was before.



Photo 6.6. Temeke T-blocks

It is of interest to note that:

- A. Many bollards and curbs, placed to discourage vehicles from leaving the road, were damaged or knocked out. The dala dalas have been slowly encroaching back on to the shoulders.
- B. Some crossing points, which were poorly located, were not optimally used.

- C. Before and after each speed bump, potholes had started to develop, mainly because of the drainage problems. However, this left the impression with Temeke municipal engineers that the speed bumps would cause potholes.
- D. Despite some of the design shortcomings, traffic on Temeke Road had calmed down and accidents had decreased significantly. Safety perceptions of NMT users had improved.

6.11 NMT Infrastructure Improvements in Morogoro (Details in Chapters 8.2, 8.3, 8.14 and 8.17)

The local authorities in Morogoro removed most of the test interventions, soon after construction, on the pretext that the road needed to be resealed. However, a few interventions remained: A Y-intersection changed to a T-junction to reduce conflicts, raised pedestrian crossings, bollards, solid concrete blocks and a bicycle parking facility. Save for the bicycle parking facilities, which had fallen into disrepair due to lack of use, the other interventions were still in reasonable condition and performing well. Raised pedestrian crossings, in some cases, were poorly located. The paint had worn off on the busy sections. However, the drains were performing well and there was no silt problem.

6.12 Performance Monitoring of NMT Infrastructure Interventions⁴¹

The performance monitoring was done in accordance with the NMT consultants' terms of reference (TOR).⁴² One month after the interventions, inspections were completed and post-monitoring data was gathered. Subsequently, post-project monitoring was repeated by the PPU, after users were familiar with the interventions.

Some of the performance indicators listed in the terms of reference proved to be unachievable or impossible to measure. For instance, trying to achieve a reduction of 10 percent in door-to-door travel times was inappropriate for most interventions. Most of the pilot interventions were too small to have a significant impact on an entire journey. Only a few missing links were provided in the overall NMT Mobility Plans for each city. The required 1 percent increase in bicycle traffic was simply too insignificant to be relevant.

The NMT consultants therefore developed an expanded and more appropriate list of indicators against which to measure the success of interventions. A sample of monitoring activities and their results, for each pilot project city, are discussed below, separately for physical interventions and the supply side interventions. The results indicate that the interventions generally contributed positively to achieving the specified performance indicators.

⁴¹ Scott Wilson, Op. cit., pp. 27-31.

⁴² SSATP Urban Transport Component: NMT, Terms of Reference, Phase II, January 1995.

Performance Monitoring in Nairobi

The post-monitoring exercise along Jogoo Road was undertaken in 1998 by the national team and the PPU. Pre-intervention (1998) and post-intervention (1999) monitoring tests were done at the steel speed bump installed on Nile Road. The PPU staff interviewed the teachers from the two nearby schools, in both instances. Other user groups were marginally involved in the monitoring exercises through workshop discussions.

The provision of a simple painted zebra crossing on Jogoo Road made no positive difference to road user behavior. It was observed that there was:

- A. Total disregard of zebra crossing by drivers,
- B. No change in vehicle speed,
- C. No reduction in traffic accidents, and
- D. An increase in pedestrian inconvenience and discomfort.

Table 6-5 below shows the impact of the traffic calming interventions on reduction in traffic accidents and driver behavior. Painted zebra crossings were ineffective for speed reduction or for traffic safety while speed bumps were effective in reducing vehicle speed.

Table 6-5. Performance indicators for pilot projects in Nairobi⁴³

Table 2: Performance Indicators on Pilot Areas in Nairobi					
Interventions	Parameter	Target	Pre-intervention	Post-intervention	Change
Zebra crossing Jogoo Road	Reduction in pedestrian accidents	10%	20 deaths 1996	20 deaths 2000	No reduction in accidents
	Change in motor vehicle driver behavior	10%	0	0	No reduction in driver behavior
	Vehicle speed reduction	10%	63 km/hr	64 km/hr	Increased speed i.e. increased risk of accidents
	Reduced average waiting time for pedestrian	50 sec	20	25-26	Insignificant change
Speed hump Nile Road	Vehicle speed reduction	10%	62 km/hr	20 km/hr	Target achieved
	Reduction in accidents	10%	0	0	No accidents in the year after construction

Performance Monitoring: Eldoret

Monitoring was undertaken in Eldoret by the Eldoret UMU and the national and international consultants. Pre-intervention data was collected in October 1998 and post-intervention monitoring was done in October 1999.

⁴³ Desk Surveys, Test Interventions, Working Paper, December 1998 and 2000.

toring was carried out in February 1999. In view of the interventions being new to the users, a repeat monitoring was carried out in November 1999. A household survey was also carried out in 1999. Not all the monitoring indicators outlined in the TOR were achieved.

The perception in Eldoret was that the project interventions were quite successful. Eldoret Town Clerk stated “The project was a resounding success. For example, it had positively impacted the accident situation, which has reduced substantially. I would say that the project was 80 percent successful.”⁴⁴ Table 6-6 shows the performance indicators for Eldoret.

On main corridors, the separation of NMT and motor vehicles by physical barriers showed good results. The carriageway was safer because of reduced conflicts between the two modes, and reduced dangerous overtaking maneuvers. On Kisumu Road, the separation was combined with the redesign of on street parking to accommodate a cycle lane, as well as the construction of bumps to reduce speeds. As a result, virtually all pedestrians moved from using the carriageway to the footpath. In addition, the construction of improved murrum footpaths elsewhere on Kisumu Road resulted in more pedestrians using the footpaths, 86 percent of the pedestrians used the paths before the improvement and 98 percent after the improvements. The upgrading or construction of new footpaths separated from the carriageway ranked highly as one of the more successful NMT interventions.

The NMT Bridge over the Sosiani River and the improvement of the NMT track, proved to be an extremely cost effective investment. This intervention had an estimated total benefit/cost ratio of 4.4, which translates into recouping investment on the route after one and a half years. Immediately after the new bridge opened, the number of cyclists on the Sosiani Bridge had increased by 100 percent.

A new traffic count, taken a year later on both routes, indicated that half the initial modal shift towards cycling faded away. The new cyclists on the NMT-only route remained but those on Kisumu road disappeared after a while. The renewed reduction in the number of cyclists on Kisumu road appeared to be quite logical because the route still had a number of other dangerous parts, which remained unchanged; solving one dangerous spot does not make the entire route safe. The initial optimism of those that resumed cycling probably died out with the renewed experience of how dangerous the other sections of the route still were. This trend was evident in Eldoret as a whole. Bicycle ownership is still high, with more than 50 percent of all households having one or more bicycles. Cycling used to be important. However, at the time of monitoring, its modal share was still around 10 percent of average daily traffic (ADT) but it could slowly go down due to the increased traffic accident risks.

⁴⁴ Scott Wilson, Op. cit., p. 18.

Table 6-6. Performance indicators for Eldoret interventions⁴⁵

Table 4: Performance Indicators In Pilot Areas: Eldoret Interventions						
Intervention	Parameter	Target	Before	Post 1	Post 2	Change [%]
Kisumu Road Bridge Raised & middle islands	Cyclists waiting time	10 sec or less	60%	30%	71%	11% change means road is safer and cyclists wait less
		10 sec or more	40%	60%	29%	Doubtful results hence repeat in post intervention 2
Kisumu road NMT count	Pedestrians footpath usage	10%	86%	99%	98%	Increased use of footpath of 12%
	On the carriageway	10%	14%	1.5%	2%	
At Harambee junction using carriageway	Cyclists count	10%	57%	7%	9%	Number of cyclists went down because day of count was national exam day
NMT count on Kisumu Road	Fewer cyclists on road	10%	100%	50%	84%	16% reduction achieved
	Cyclists on new track	10%	N/a	50%	16%	
	Fewer pedestrians on road	10%	40%	0.5%	0.4%	Pedestrians now use NMT track
	Pedestrians on new track	10%	60%	99.5%	99.6%	
Street Links - Uganda Road Muliro-D link	Cyclists on track	1%	N/a	12%	7%	Majority of cyclists prefer carriageway to cycle tracks
	On carriageway	1%	N/a	88%	93%	
Kago-Tagore link	Cyclists on track	1%	N/a	8%	5%	Majority of cyclists prefer carriageway to cycle tracks
	Cyclists on carriageway	1%	N/a	92%	95%	
Tagore-Paul's Bakery	Cyclists on track	1%	Not measured	Not measured	5%	Pedestrian monopoly of cycle track
	Cyclists on carriageway	1%	Not measured	Not measured	95%	
Walking time Market road to Footbridge	Pedestrian speed minutes	-	8	6	4	Faster speed due to improved surface
	Km/h	-	2.25	3.0	4.5	

Performance Monitoring: Traffic Calming Measures in Temeke⁴⁶

A package of traffic calming interventions was implemented along Temeke Street. The street previously displayed a chaotic traffic environment with conflicts between mini-buses, trucks, cars, pedestrians, bicycles and handcarts. At that time, the condition of the road was good, allowing speeds of up to 70km/hour.

⁴⁵ Desk Survey, Test Interventions Working Paper Report, December 2002, 2002.

⁴⁶ I. Kisisa, Pilot Projects on Urban Mobility and Non-Motorized Transport. Traffic Calming Experiments in Tanzania, Prepared for the National Seminar, 15-16 December 1998.

Interventions along the road included raised pedestrian crossings, pedestrian refuge islands, intersection realignments, bumps and bus bays. At that time, the objective was to reduce vehicle speed (while keeping the traffic moving), reduce road shoulder chaos and eliminate dangerous intersections. The works were implemented and monitored by the PPU and the NMT Consultants. Table 6-7 below shows the results of monitoring.

The traffic accident data provides a clear indication of the positive contribution that relatively inexpensive spot interventions can make towards improved road safety.

Measuring the Success of the Interventions in Temeke

When interviewed, the Temeke PPU members were of the opinion that the hard work they had put in, to sensitize beneficiary communities as well as the physical interventions, appeared to have slowly persuaded people to regard the pilot project interventions as beneficial. Appreciation of the project had grown, judging from some communities calling for traffic calming measures in their areas, as well as letters to newspapers and to the city authorities expressing similar preferences. Another measure of success is the fact that another road project in Dar es Salaam, funded separately by the Japanese International Cooperation Agency (JICA), included a significant number of NMT measures.

Table 6-7. Performance indicators for traffic calming in Temeke⁴⁷

Table 5: Performance Indicators In Pilot Areas: Temeke Traffic Calming					
Intervention	Parameter	Target	Before	After	Comment
Raised Zebra Crossing	Vehicle speed	30km/h	50km/h	14-25 km/h	Speed depended on shape and location of crossing. Target achieved
Speed hump	Vehicle speed	30km/h	50km/h	10km/h	Target achieved
Pedestrian refuge island	Vehicle speed	40km/h	60km/h	35km/h	Target achieved.
Changombe St. junction re-alignment	Traffic conflicts	Not specified	Approx 16 conflicts between 7am and 6pm	3 conflicts	Significant reduction in conflicts
Everett St. junction re-alignment	Traffic conflicts	Not specified	30 conflicts	3 conflicts	Significant reduction in conflicts
Combined impact	Traffic accidents	10% reduction	12 accidents in first half of 1996	0 accidents in first half of 1997	Target achieved

⁴⁷ Scott Wilson, Op. Cit.

An article in the local daily newspaper narrated a dramatic story of students who, in a show of solidarity and civic disobedience, gathered on one of the dangerous roads close to their school. They literally lay on the pavement ignoring the on-coming traffic to demonstrate their anger at the authorities for not taking action against speedsters after one student died in an accident. The city eventually relented and promised to construct speed bumps to slow down traffic. This is an example of how communities sensitized to the benefits of NMT infrastructure, will likely put pressure on government to provide for such infrastructure.

Performance Monitoring: Morogoro

Unfortunately, most of the test interventions in Morogoro were removed soon after their construction, on the pretext that the roads required re-sealing. The few interventions that remained include the re-configuration of a Y-junction, raised zebra crossings, bollards, solid concrete blocks and a bicycle parking facility. The bicycle parking lot had fallen into disrepair due to lack of use. However, the remaining NMT interventions were in reasonable condition and performing well. The drains were also performing well, with no visible silt problems.

The PPU, with the assistance of the national team, persuaded two programs funded by the World Bank, the Integrated Road Project (IRP) and the Urban Sector Road Program (USRP) to include NMT infrastructure within their projects in Morogoro. The final design included separated pedestrian and cycle tracks, raised zebra crossings, dala dala stops, and open drains separating motor vehicles from NMT. On sections of road, with a reserve > 3 meters, the physical segregation of both modes was achieved by constructing pre-cast concrete open drains, raised curbs and bollards. A substantial number of roads, under the USRP, have NMT infrastructure facilities and traffic calming measures. By 2003, the 3 kilometers long Turiani Road was reconstructed with a 2x3 meter carriageway with open drains and a separate bi-directional cycle track with a walkway on one side of the road. This indicates that over time, it is possible to achieve the implementation of NMT facilities as knowledge and experience change the attitudes of both the professionals and the decision makers.

6.13 Effectiveness of the Interventions

The test interventions provided significant practical professional experience on the design of NMT infrastructure, particularly suitable for SSA. The local authorities understand the implications of some of the simpler interventions quite well and therefore, there is scope for implementing them on a wider scale. These measures include traffic calming devices such as speed bumps, bollards and raised curbs. Interventions such as raised zebra crossings were particularly effective. However, the complexity of designing effective NMT infrastructure in SSA should not be underestimated. A keen understanding of human behavioral patterns is essential. Designs, which work in the developed world, are not necessarily appropriate for SSA, where local authorities do not maintain the infrastructure, driver behavior is far less predictable and traffic law enforcement is weak.

Of particular concern was the number of collisions occurring between motorized vehicles and NMT infrastructure. Pedestrian islands at new crossing points appear to have been particularly vulnerable. The damage to vehicles must have resulted in considerable cost and inconvenience to the vehicle owners. The NMT consultants argue that driver behavior appeared to improve during the monitoring period, with fewer collisions as they became more aware of the obstructions. This seems to be a rather hard way for the drivers to learn safe driving. Once the reflective paint had worn off bollards and the concrete blocks, it was not surprising that there were more collisions, particularly at night and during times of poor visibility. Most locations do not have street lighting and many vehicles do not have or do not use headlights.

Encroachment of vendors onto NMT paths is a significant problem that can undermine the effectiveness of interventions. This can only be controlled through increased collaboration between those in municipalities responsible for planning and constructing NMT infrastructure, and those managing the activities of the small-scale private sector.

6.14 Aggregate Impacts of Traffic Calming⁴⁸

The scope of the pilot projects was somewhat limited and did not include an area-wide approach. However, it was at least possible to implement a reasonably complete package of traffic calming along one entire collector street, Temeke Road in Temeke. This road is about 2.5 kilometers long and was improved with a package of five raised crossings, four bus bays, three crossing islands, 1 Y-junction reconstructed to a T-junction, 2 speed bumps and a shoulder separation with T-blocks on part of the carriageway. The assessment of the aggregate effect of a package of interventions on traffic safety is certainly more convincing than an analysis of individual spot interventions.

Table 6-8 below shows the number of traffic accidents along Temeke Road from 1995 to 1999.⁴⁹ The traffic accident data was compiled by the traffic safety unit (TSU) of the Dar es Salaam municipality independently. They used the MAAP (traffic accident analysis software) developed by TRL (UK). The TSU stated that non-fatal accidents in 1995 were probably a bit under-recorded. In other years all fatal accidents, all accidents involving serious vehicle damage and most serious non-fatal other accidents are believed to have been recorded. Generally, light accidents are not recorded. Traffic calming interventions started in 1996 and were completed in 1998.

It was possible to reduce the accidents by a factor of 10. It is impossible to eliminate all accidents and some fatal accidents may still occur. Yet in spite of very high accident rates in SSA, traffic calming is neither popular nor widely practiced. It is not clear why this is the case. Part of the explanation may be that there is reluctance at decision-making levels to seriously con-

⁴⁸ De Langen and Tembele, *Op. cit.*, p. 210.

sider systematic full-scale traffic calming, as the pilot projects experience indicated. Traffic calming is often perceived as being anti-motorized traffic.

Table 6-8. Safety improvements on Temeke Road

Year	1995	1996	1997	1998	1999
Total Number of Accidents	54	67	20	9	6
Total Fatalities	5	1	0	0	1

Large as the reduction in accidents appears at first glance, it is not strange. The accident rate in African cities is around 25 to 40 fatal accidents per year per 10,000 motor vehicles. Most of the victims are pedestrians, killed mostly while crossing a road.⁵⁰ In contrast, traffic accident fatality rates in European and American cities are 1 to 2 fatalities per year per 10,000 vehicles. The similar rate for Africa is 15 to 30 times higher.

Newly constructed raised zebra crossings initially led to severe complaints by car drivers who demanded the demolition of the crossings immediately. Their defense, by the community members in the area who had been initially involved in the planning and implementation process, was so strong that the municipal authorities yielded to the complaints. The resolution of the conflict came from small changes in the design, making it less uncomfortable for drivers, but not less effective.

After some time, traffic accidents on this road almost disappeared. All parties appreciated the increased safety situation. What was initially seen as a conflict of interests was in fact a common problem and addressing the problem had created a win-win outcome.⁵¹

A suitable program of road and intersection re-design and traffic calming can almost eliminate serious pedestrian and bicycle traffic accidents. In the case of systematic traffic calming on a 2-kilometer long collector road section, the findings indicate that accidents are reduced by a factor of 10 (ten times less than before). This means that the accident risk per vehicle kilometer on that road was similar to the European/US level.⁵²

⁵⁰ TRL Report No. 265, 1997 and Report No. 839, 1984.

⁵¹ De Langen and Tembele, p. 5.

⁵² Ibid, p. 20.



Photo 6.7. Traffic calming with RZC bollards and T-blocks separating MV and NMT



Photo 6.8. Traffic calming islands



Photo 6.9. Bus-bay with T-blocks bollards separating traffic lanes



Photo 6-10. Traffic calming with medians and bollards



Photo 6.11. Intersection re-alignment with island



Photo 6.12. Properly designed bus-bay

6.15 General Design and Implementation Issues⁵³

The guiding criteria for intervention selection and implementation were to ensure safety, efficiency and effectiveness. Several factors influenced the detailed designs: ease and cost of maintenance, flexibility, aesthetics, strength, visibility, cost, availability of materials and working methods. Although most of the equipment employed in the construction was not too expensive, smaller cities such as Eldoret could not even afford some of the low-cost implements such as hand rollers, hand sprayers, durable paint, concrete mixers, moulds for culverts and spare parts for the machinery.

Field-testing of the spot interventions indicated engineering design deficiencies in some of the physical interventions. This included a lack of durability of some elements of the infrastructure particularly in heavy traffic areas. These included continuing collisions between motor vehicles and NMT infrastructure such as bollards and T-Blocks, theft of road furniture and excessive maintenance requirements. Pedestrian infrastructure was not used as the designers thought it would be. Some pedestrians continued to use shortcuts, even if it involved walking across difficult terrain or coming into conflict with motor vehicles.

The deficiency of some of the designs was expected, given the testing nature of the interventions. Some significant lessons were learnt as to how the designs of the NMT infrastructure can be improved for local conditions. What is more important is the effective dissemination of these lessons learnt.

The international team, the national teams and the PPU's undertook the design of the interventions jointly. The design process involved detailed topographical surveys of identified sites, site visits, traffic counts and other specific requirements for the prioritized interventions. In the case of Kenya, the NMT consultants submitted the proposals to the Urban Development Department (UDD) and the KUTIP consultants for comments. The design review process included the design workshops attended by the NT, local government officials, PPU's, road users and other stakeholders. The workshop recommendations were incorporated in the designs in accordance with the national standards.⁵⁴ Thereafter, the designs were submitted to the respective local authority for the normal development approval process.

The initial design proposal suggested a narrow 3.0-meter carriageway past the island. Most drivers as well as traffic engineers of Dar es Salaam considered this too narrow. Having the entire carriageway deflection past the island at a constant width of 3.0 meters was seen as too restrictive. However, computer simulations of vehicle maneuvering indicated that even the largest truck/trailer combinations could pass on the 3-meter lane without difficulty, provided they

⁵³ Scott Wilson, *Op. cit.*, pp. 15-16.

⁵⁴ For example, the Standard Specifications for Road and Bridge Construction of the Kenya Ministry of Transport and Communications, 1986 and Road Design Manuals, Parts 1 and 2.

reduce their speed to around <30 km/hr. To a large degree, this perception reflects the carriageway width which people are accustomed to.

Soon after construction, the curbstones at the test site, which align the carriageway at the road shoulder, were damaged by large trucks. This was quite probably the result of the unwillingness of the drivers to slow down enough. The strength of the initially constructed curbstone was insufficient to survive being hit by heavy trucks. Constructing the carriageway/shoulder separation past the islands with T-blocks would have been better. Such a separation would be less vulnerable to damage and in addition, it commands more respect from drivers (fear for damage to vehicle tires) and therefore encourages lower speed.

The pilot projects experience demonstrates that the design of some NMT infrastructure, while appearing to be straightforward on the surface can be extremely complex. This is due to the need to understand the behavior patterns of non-motorized and motorized transport users, and the need to factor into the design the NMT infrastructure, the lack of maintenance capability and low levels of law enforcement.⁵⁵

6.16 Increasing the Ownership and Use of Bicycles

Most cycling in the pilot project cities was on mixed traffic roads, with average motor vehicle speeds of 20 to 30 km/hr and maximum speeds of 50 km/hr. With relatively simple and low-cost measures, cycling could be made attractive, and available to a much larger proportion of the population. In cities with a significant amount of bicycles, the highest potential for an increase in cycling is among adult women and secondary school students. Many adult men already cycle. In non-cycling cities, young adult males should be the first target group.

Determinants of Bicycle Ownership

The determinants of bicycle ownership were included in the household travel surveys. Results indicated that the two determining factors were traffic safety for the cyclists and the affordability of a bicycle. However, the second factor only comes into play where a large number of potential cyclists feel it is safe to cycle⁵⁶. The findings also showed that in Tanzania and Kenya, apart from a very small high-income population group, social status aspects were not a significant reason for not cycling. However, in West Africa the status aspect plays a more widespread role as a constraint to urban cycling⁵⁷.

⁵⁵ Scott Wilson, *Op. cit.*, p. x.

⁵⁶ G. Sambali et al, *Determinants of Cycling in Medium and Large Cities in SSA*, Proceedings of the World Conference on Transport Research, Antwerp, 1998.

⁵⁷ J. M. Cusset, *Low Cost Mobility in West African Cities*, Proceedings of the Expert Group Meeting on Low Cost Mobility in African Cities, Delft University, Delft, 2000.

Personal incomes and travel cost are significant factors in bicycle ownership and mode choice. Due to the low average value of time and household incomes, 77 percent of all costs are direct costs, although almost half the daily trips are on foot. There is a strong imbalance between the cost distribution and the modal shares: Motorized traffic accounts for only 6 percent of all daily trips (9 percent of all trip/km), but requires 52 percent of all direct financial costs and 41 percent of all total costs of daily travel including the value of time.⁵⁸

A reliable estimate of the total income of the inhabitants of the area is difficult to make. A report by the Economic Research Bureau (ERB) of the University of Dar es Salaam mentions an average per capita annual income of US\$139 in 1995 for Tanzania, as estimated by Tanzania National Bureau of Statistics. ERB also estimated that the average annual per capita income in West Tanzania was US\$165 and US\$400 in the most affluent cities of West Tanzania. A detailed household budget study estimated the per capita income in Dar es Salaam at 2.2 times the national average, or US\$350 in 1994.⁵⁹ Temeke is a typical average part of Dar es Salaam and the inhabitants spent an estimated 25 percent of their household income on direct costs of daily transport, excluding the value of time.

The bicycle is the only mode of transport with a significant potential to reduce the expenditure on transport in Temeke and simultaneously increase the household mobility. The bicycle accounted for 3 percent of the daily trips and 3 percent of the trip/km, at only 1 percent of the total costs. Direct costs of cycling are about one-third the cost of the bus and the bicycle could cover the same trip distances in approximately the same travel time. The ability to cycle safely within Dar es Salaam could reduce household expenditures on daily transport needs from 25 percent to around 10 percent of household income and therefore, have a major impact on poverty alleviation.

Increased Volume of Cyclists⁶⁰

In the first 3 months after the construction of “medians” in Eldoret, there was a 13 percent increase in cycling (180 cyclists per day, inbound; same weather conditions). Bicycle network improvements were made simultaneously on Uganda Road and on Kisumu Road (parallel north-south corridor to the CBD). Therefore, this increase was not in diverted traffic but represented a shift from mini-bus to bicycle. A sudden change of this size was possible in Eldoret since bicycle ownership was already high.

However, subsequent bicycle use had started to go down due to increased traffic hazards, but can still pick up quickly if the conditions for cycling improve. After one year, most of the in-

⁵⁸ De Langen and Tembele, Op. cit. p. 81.

⁵⁹ Developing a Poverty Base Line in Tanzania, TNBS and Oxford Policy Management Ltd., Dar es Salaam, May 2000.

⁶⁰ De Langen and Tembele, Op. cit., p. 178.

crease in cycling over the Sosiani Bridge had disappeared, probably because the rest of the cycle route along Kisumu road was still too dangerous (see Chapter 8.5).

After the implementation of the cycle tracks along an urban corridor, Eldoret municipality was unable to enforce shopkeepers to leave the verandas in front of their shops free for use as a walkway. In retrospect, it was in fact wishful thinking that this would be possible. Much more space is required for pedestrians at this road section than was available under the verandas of the shops. As a result, the pedestrians used the new “bicycle” track and almost all cyclists continued to use the carriageway, the new track being full of pedestrians. Today, it has become a walkway.⁶¹

Increased Cycling in Morogoro

A study of mobility changes in Morogoro was undertaken in order to assess the impact of the bicycle ownership promotion activities.⁶² These activities included credit facilities for bicycle purchase, bicycle-parking facilities, teaching cycling to students and bicycle rentals. The monitoring was based on data obtained through household surveys undertaken in 1995 and in 1998. There was a substantial increase in the use of bicycles for trips >5 kilometers. Table 6-9 below shows the key results of the study.

Table 6-9. Mobility changes in Morogoro 1995 -1998

Indicator	Target	Before	After
Mobility of Residents	Not specified	1.9 trips/person/day	2.5 trips/person/day
Use of bicycles for trips >5 Km	1% increase	55% of cycle trips	79% of cycle trips

Bicycle Purchase on Credit

Providing incentives to employers to establish bicycle credit or savings schemes was considered. However, the market conditions and business attitudes were unfavorable to credits pre-financed by employers for their employees. However, bicycle credit purchases through employee savings schemes were more successful. In Eldoret, where many successful savings societies have already existed for decades, the Raymonds Savings and Credit Cooperative Organization of Raymond Textile Factory (a large private firm) started a bicycle credit scheme for its members. SACCO offered 300 bicycles to its members on a credit purchase plan and all the bicycles were sold within two weeks.

⁶¹ De Langen and Tembele, *Op. cit.*, p. 190.

⁶² G. I. Sambali, *Urban Travel Situation in Morogoro Municipality*, Prepared for the National Seminar on Bicycle Promotion, August 1999.

Consideration was given to what incentives could be offered to bicycle dealers to enable bicycle sale-on-credit. However, this was against the business practices and methods at the time. Generally, the market moves away from small credits to poor clients who are considered to be too risky by the lenders. The pilot project experience indicates that micro-loans for bicycles are not a suitable instrument to increase bicycle affordability to the poor or to specific underprivileged groups. The overheads and risks associated with such micro-loans, for both the borrower and the lender, were found to be prohibitive under the prevailing circumstances. However, this does not make it impossible to influence bicycle affordability in a significant manner. At the national level, an uncomplicated instrument is readily available: a bicycle price policy, consisting of complete tax exemption (import duties, VAT, user tax) and targeted purchase subsidies for specific groups, such as women.⁶³

Bicycle Hire-Purchase

The PPU's discussed the idea of some incentives for hire-purchase contracts. There was a positive reception of the idea by hirers in Morogoro. Their financial position was too weak in 1999 to allow them to finance enough bicycles and only two were sold on hire purchase.



Photo 6-13. Bicycle hire shop in Morogoro advertising ladies bicycles

Interventions to increase ownership of bicycles in Eldoret were quite successful, although the biggest constraint was affordability, even with project-funded support. Purchase required the payment of a deposit, an insurmountable problem to many potential buyers. The bicycle user platform felt that if they had more control over the project funds, they would have been able to leverage the funds more effectively to maximize the number of bicycles bought.

Promotional Sale of Women's Bicycles

Promotional sale of bicycles to women (of women's bicycles) and to children entering secondary schools, giving a 15 to 20 percent discount, was quite popular in Morogoro. The response by women showed that there was a significant potential for more women cycling, now less than 5 percent of all cyclists in Morogoro. The response to the scheme also showed that the price elasticity of the bicycles is high, even a small price discount creates a significant increase in the number of buyers. Any reduction in the cost will have a significant effect on ownership and use. The authorities could consider measures such as exempting bicycles from import taxes or VAT.

⁶³ Ibid, p. 27.

Bicycles for Hire



Photo 6-14. Morogoro cycle hirers Association

The "Bicycles for Hire" business in Morogoro is thriving. There were some 200 micro-entrepreneurs, with about 1,500 bicycles available for rent. They captured a market share of about 6 percent of all daily trips, roughly about half the market share of minibus trips. The bicycles can be rented on an hourly, daily or weekly basis.

The pilot projects tried a support program to for bicycle-hire operators. There was a positive response to this program, especially to the initiatives of the hirers themselves. Ladies' bicycles, previously not used for hiring, turned out to attract more women as clients. To the hirer's surprise, men also liked them, for their greater riding convenience.

Using the opportunity created by the bicycle promotion carried out in Morogoro, the bicycle-hire operators themselves took important initiatives and established a "Bicycle Hirers Association". They also undertook successful innovations such as the introduction of women's bicycles.⁶⁴

Cycling Lessons in Secondary Schools

This program was very popular, among girls as much as among boys. This is an activity worth sustaining in the long term.

Bicycle Parking

This was a difficult exercise as it involved changing the habits of bicycle users. The success of bicycle parking depends on the location and the risk of theft. Parking schemes had a lower than expected use. In Morogoro, even a small fee had an inhibiting effect.

In Eldoret, it was initially agreed to build a bicycle parking lot. Subsequently the PPU and the NT designed the parking lot and awarded the contract for the construction of the parking lot to a local contractor. However, the Eldoret City Council later allocated the same space to traders who put up "lock up shops". Hence, the idea of the bicycle parking lot was abandoned.

⁶⁴ De Langen and Tembele, Op. Cit., p. 5.

General Bicycle Promotion and Publicity

Other promotional activities were undertaken to strengthen the image of the bicycle as a modern and attractive mode of urban transport. A bicycle race staged for women was a huge success and resulted in women feeling that a bicycle could increase their ability to move freely around when and where they needed.

7 PRIVATE SECTOR PARTICIPATION

7.1 Voluntary Beneficiary Contribution: Bollards in Nairobi

There are opportunities to engage the private sector in the implementation of NMT measures. For example, the businesses in downtown Nairobi have commonly provided bollards to prevent vehicles from parking on the paved walkway (footpath). The installation of the bollards has made it convenient for the shoppers to enter the shops by preventing motor vehicles from interfering with pedestrian access to the businesses. The shop owners feel they have benefited from donating the money for bollards. There is an opportunity here to engage the private sector more rigorously.

7.2 User Contributions: Yombo River Bridge I, Temeke⁶⁵

Temeke has several unplanned parts, due to very rapid population growth and unplanned expansion. Most of these areas have major accessibility problems. A major problem for the NMT users was that the direct NMT route towards the center of the Temeke ward (schools, markets, jobs, bus station) comes to the Yombo River (barrier), which is difficult to cross without an NMT bridge. Since the direct benefits of the NMT bridge were obvious, the local community, in cooperation with the PPU with clear terms of reference, established a specific user platform. The Local User Platform (LUP) short-listed the construction of the Yombo River NMT bridge. The agreements stated that there would be a significant contribution from the local community, financially or through labor, towards the cost of the bridge, and in addition, the community would take care of its maintenance. During the construction period, the LUP volunteered to store bags of cement in one of their member's houses. They counted the bags brought, guarded them at night, registered them when they were taken out and monitored how they were used on site. The bridge was successfully constructed with labor contributions from the users.

7.3 User Contributions: Yombo River Bridge II, Temeke

The Yombo bridge case study shows how information about the cost of the bridge helped the user platform to mobilize funds for further construction works. Having succeeded in getting the first pedestrian bridge built (Yombo I), residents urged the user platform to build a second one down stream. Construction costs were TShs.700.000. The PPU was willing to assist on the condition that the community should substantially increase its own contribution, compared with that of Yombo Bridge I, and the user platform would provide a work plan, with allocation of tasks indicating the various sources of funds and labor. The user platform approached the District Commissioner of Temeke, who then approached the Regional Commissioner of Dar es Salaam (both are stakeholders). The latter agreed to provide TShs.500.000 towards the construction of Yombo River Bridge II. User Platform raised

⁶⁵ De Langen and Tembele, Op. cit. p. 150.

TShs.100.000. With this amount in their own bank account, the user platform felt that they had now raised a substantial amount of the required capital and so informed the PPU. The PPU contributed the remaining TShs.100.000 from the pilot project funds and the Yombo Bridge II was built. The lessons learnt were that because the process and budgets were transparent, the user platform was fully aware of the costs, conditions and the players. Therefore, they were able make a rational and pro-active input.

7.4 Yombo River Bridge I: Repairs



Photo 7.1. Meeting of the Yombo River Bridge User Platform

The first rainy period after construction, the bridge functioned well. However, in October 1997, extremely heavy rains damaged one of the ramps. The same rain, nicknamed “el-Niño”, washed away a large number of road bridges in Tanzania and Kenya. This required repair was an unexpected early test for the maintenance capability of the community.

The municipal team communicated its willingness to pay for the cost of materials required to repair the damage (approximately 50 percent of the total cost), if the community was willing to do the construction work voluntarily. During the

dry period after the damage, a long period of “struggle” between the municipality and the community developed. The community implicitly decided to test whether if they refused to do their part, the municipal team would, out of embarrassment, repair the bridge on its own. After six months, it had become clear to the community that the bridge was not going to be repaired. The community then made a deal with the PPU whereby the bridge would be repaired by them with the municipality paying for the materials and supervision. The users (the community) paid through volunteer labor contributions. The quality of the work performed by volunteer labor turned out to be quite satisfactory.

7.5 Private Sector Initiatives for NMT Planning: Nairobi Westlands Residents Association

Nairobi Westlands Residents Association had developed proposals to improve mobility by accommodating all forms of transport modes. These improvements would be funded by the private sector. The association had lobbied, in vain, with the city council with a view to get permission and an opportunity to test these interventions in its neighborhood. The association's representatives indicated some frustration with the inability of the Nairobi City Council to communicate development issues to its constituencies in general and stakeholders (in the SSATP NMT Pilot Project) such as the Westlands Residents Association, in particular. Although they had been consistently engaging the city council to generate mo-

bility plans with a specific slant on pedestrians and cyclists, the city council had not been fully candid with them because they had not even revealed the existence of the NMT Pilot Project with similar goals, from which they could have tapped a considerable wealth of information. The Westlands Association had been groping in the dark to generate solutions, with an emphasis on non-motorized transport, for their area.⁶⁶

7.6 Increasing the Ownership of Bicycles

The primary constraint to bicycle ownership is its high cost to the majority of the people given their low household income. The bicycle costs approximately four times the monthly minimum wage. Consequently, nearly fifty percent of the households cannot afford to buy a bicycle. The poor do not qualify for buying on credit from financial institutions and obviously, they do not have the money to buy without credit! In this regard, the private sector can play a significant role, provided there are demonstrable guarantees for repayment.

In general, the employers were not willing to finance the purchase of bicycles. However, where there were well established "employee savings associations", the schemes were quite successful. In Eldoret, the bicycle ownership campaign, through Raymonds Savings and Credit Cooperative Society in Raymond Textile Factory, was highly successful. The society offered to sell 300 bicycles on credit and these micro-loans were all taken in a short period of only two weeks.

The private sector must be an essential partner in any effort to increase bicycle ownership and use in SSA cities. Current financing habits and attitudes are not favorable for allowing micro-credits to the poor for this purpose. Under these circumstances, the only potential method to increase bicycle ownership is to include a micro-credit component in future NMT infrastructure projects financed by the World Bank.

7.7 Bicycles for Hire Enterprises in Morogoro

In 1999, bicycle hire business in Morogoro was substantial and thriving, with about 200 micro-entrepreneurs operating with about 1,500 bicycles. Cycling accounted for 23 percent of all daily trips. Bicycle hire shops captured about 25 percent of all the bicycle trips.

7.8 Cycling by Women

Partly because of the bicycle use hierarchy in the household and partly because of cultural traditions, many women do use bicycles. In Morogoro, women accounted for less than 5 percent of the cyclists. Encouraging women to cycle has a significant long-term potential advantage to increase household mobility. However, such efforts must be accompanied by increased traffic safety and bicycles designed to suit the African conditions.

⁶⁶ Interview with Mr. Shirish Khan, Member of the Westlands Association, Nairobi in May 2002, as referenced in Scott Wilson, Op. cit. pp. 41-42.

The NMT program introduced the promotional sale of bicycles to women and to children entering secondary schools. The purchasers received 15 to 20 percent discount. This scheme was very popular in Morogoro. The experience not only indicates the price elasticity of bicycles but also price changes of this value can create significant new demand and therefore, new bicycle users.



Photo 7-2. Morogoro cycle hirers association



Photo 7-3. Bicycle hire shop in Morogoro advertising ladies bicycles

8 EXAMPLES OF INTERVENTIONS⁶⁷

8.1 Background

Applicability of the Examples

The examples discussed in this chapter, are all drawn from the pilot projects cities, Dar es Salaam, Morogoro, Nairobi and Eldoret. Although these examples represent a significant variety of traffic conditions, they do not cover them all. Nevertheless, they are typical of the conditions in most medium-sized cities and for the areas of the big cities, outside the Central business district.

Benefit-Cost Calculations –Assumptions

All costs and benefits are stated in USD equivalents of Tanzanian shillings (Tsh) and Kenyan shillings (Ksh) to facilitate international comparisons. From 1996 to 1998, the exchange rate of Tsh to the USD varied from $\pm 550:1$ to $660:1$, and that of Ksh from $\pm 50:1$ to $60:1$.

Total annual cost includes the annualized capital cost and the maintenance cost. To calculate the annual cost of capital (yearly costs of interest and depreciation), an interest rate (i) of 10 percent was used for constant costs, excluding inflation. The lifetime of the interventions (N) varies according to their type. For most interventions, such as raised zebra crossings, speed bumps and traffic islands, $N=20$ was assumed. For a few other interventions, such as NMT Bridges, $N=20$ was assumed. With proper maintenance, the effective lifetime of the interventions would be higher than expected and therefore, the annual cost of capital would decrease. With $i = 10$ percent and $N=10$, the annual costs were 16.3 percent of the investment. With $i=10$ percent and $N=20$, the annual costs were 11.7 percent of the investment.

Maintenance costs depend on the type of road or structure. The assumed annual maintenance cost for interventions vulnerable to pavement damage or collision damage was 5 percent of the total capital cost. For interventions, such as the NMT bridges, it was 2 percent.

Value of Time

A realistic estimate of the economic value of timesaving is quite complex. It depends on whether the time saved can be used for productive activity and on the estimated value-added product per time unit, using wages as a proxy. In Tanzania and Kenya, official employment rates are not very useful for assessing the potential for productive use of time. Most low-income adults are engaged in a variety of personal activities that are essential services to the household

⁶⁷ Examples and discussions in this chapter are derived from de Langen and Tembele, Op cit., Chapter 13.

economy. This is particularly true of women. Therefore in the calculations, all the time savings of adults (age => 15) must be taken into account. The calculations were based on minimum unskilled wage, at 10 hours per day. To avoid over-estimating the value of timesaving, the productivity per hour was assumed low and therefore, only 50 percent of the timesaving were taken as productive time. It translates to US¢ 15-20 per hour in Nairobi, US¢ 10-15 per hour in Eldoret, US¢ 10-14 Dar es Salaam and US¢ 8-12 in Morogoro. Finally, for computing B/C ratios, this was rounded down to US¢ 10/hour.

Walking Time Savings

For the calculation of temporal benefits, a timesaving of 4 minutes per pedestrian per kilometer was assumed for the improvement of a route from a bad condition (rough pavement forcing pedestrians to make significant mini-detours) to a good condition (flat, unobstructed). This corresponds to an increase in average walking speed from 3.5 to 4.5 km/hr. An increase in walking speed from 3.0 to 4.0 km/hr corresponds to a 5 minutes time gain per kilometer and from four to 5 km/hr to a 3-minute time gain/km.

Cost of Accidents

An estimate of the costs of accidents is also difficult to compute. The following costs were used in the calculations for all the interventions:

- A. US\$3,000 per person killed in an accident 3,000 (UK = US\$132,000),
- B. US\$250 per person seriously injured (UK = US\$16,000),
- C. Zero cost light injury (UK = US\$15,000), and
- D. US\$300 for vehicle damage (UK = US\$1,500)

These estimates were based on current average incomes and on repair costs of secondhand cars in Tanzania and Kenya. These costs are quite low, compared to costs in the European countries. The costs were kept at this low level in order to avoid over-estimating benefits. For a fatal accident, the estimate is based on direct cost plus loss of economic output of the victim. In earlier studies, the Kenyan Ministry of Transport had used much higher figures: US\$25,000 for a fatality, US\$400 for a serious injury, US\$160 for a light injury and US\$1,600 for vehicle damage. Hans Adler estimated these costs at US\$200 for light injuries, US\$1,900 for serious injuries and US\$12,300 for fatalities in Kenya. His study recommends that accident cost estimates for project appraisal in developing countries be limited to property damage (vehicles and other), medical costs and loss of output only.⁶⁸ The difference in the person-related costs, between the Kenya/Tanzania and UK, corresponds approximately to the difference in per capita incomes (1:50). For vehicle damage, the cost difference is much smaller.

⁶⁸ Hans Adler, *Economic Appraisal of Transport Projects*, World Bank, 1987.

Costs of light injury were not included because light injuries are seldom reported with any accuracy in official accident statistics. In general, accidents appear to be under-reported and many disputes are settled informally. Even in Dar es Salaam, where a good accident recording system has been in place since 1995, it was sometimes not possible to retrace some accidents, which were reported by people in the pilot project area, from the police accident records.

In comparison to the numbers used in other studies, the cost estimates here are on the lower side, and the cost of accidents used in these examples can be considered as lower limits.⁶⁹

8.2 Un-obstructed Walkway, Morogoro

Background

A narrow side street off the main road in the town center, opposite the intercity bus station, is an important pedestrian shortcut route to the northern part of the town. However, using the walkway was often difficult because the narrow walkway was blocked by street traders, parked vehicles or mud in the rainy season.

Conditions Prior to Interventions

The conditions prior to the interventions were:

- A. In front of shops along the Old Dar es Salaam Road, shopkeepers built a concrete pavement. The other walkways were compacted murram. Vehicles often parked on the side street. Potholes accumulated water when it rained and transformed the “walkways” into areas difficult to walk through.
- B. The estimated number of pedestrians crossing at the intervention spot was 7,300 in 12 hours. The maximum motor vehicle flow along the Old Dar es Salaam Road was 870 veh/hour (both ways), during 10-11 am. Most vehicles are used commercially rather than for journey-to-work.
- C. Estimated average speed of vehicles was 43 km/hr.
- D. Table 8.1 below shows the 1996 modal split for the traffic along the road. These counts are slightly distorted as vehicle occupancy was not counted.

Table 8-1. Modal split on Old DSM Road, Morogoro, 1996*

Mode	Walk	Cycle	Bus	Minibus	Car	Truck	M Cycle	%
Number of units	40	36	1	1	7	12	3	100

* Vehicles were counted as one unit, not counting the passenger occupancy

⁶⁹ Overseas Road Note 10, Costing Road Accidents in Developing Countries, TRL, 1995.

Problems

Some of the problems encountered were:

- A. Pedestrian crossing was unsafe. Non-fatal accidents were common.
- B. For vulnerable pedestrians (young, parents with children, old or disabled) waiting times were long and protected waiting areas were not available.
- C. Parked vehicles and street traders often blocked the walkways.
- D. The pavement of the side street was in bad condition. Using it during the rainy period was difficult.

Objectives of Interventions

The objectives were:

- A. To implement the walkways in combination with raised zebra crossings,
- B. To enable unobstructed pedestrian movement on the walkways, through the shortcut route, and to stop pedestrians walking on the carriageway, and
- C. To create safe traffic conditions, in particular for pedestrians and cyclists crossing the street.

Interventions

These interventions were implemented in two stages. First, motor vehicles were prohibited from entering the side street and secondly, a raised zebra crossing was constructed on the main road in order to give priority to pedestrians. The effects were satisfactory, restored traffic safety and attraction to the short cut route increased. However, some problems, such as vehicle parking on the pavement, remained. Street traders increasingly blocked the pedestrian traffic on the side street, the side street being now a better location for them, in view of the increased number of pedestrians. The steepness of the initial slope of the raised zebra crossing (1:6) caused many drivers to stop completely before driving over it slowly. This occasionally created short queues.

The second step was to make a number of changes to rectify the above problems. These changes included modifying the slope of the raised zebra crossing to 1:9 (gentler slope), constructing more bollards to prevent vehicle parking on the walkway, constructing a concrete slab pavement on the walkway along the side street, and in consultation with the street traders, demarcating the areas with lines of high wooden poles, indicating where they could set up shop. The Figure 8.1 below shows these network improvements.

Figure 8-1. Pedestrian network improvements

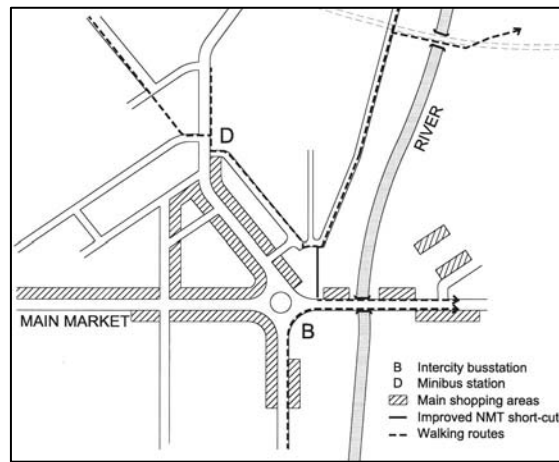

Cost of Interventions

The total cost of the above interventions, including the raised zebra crossing, was US\$ 4,500.



Photo 8-2-1. Street traders blocking walkways and entrances before improvements



Photo 8-2-2. Side street after improvements and arrangements with traders

Impact of Interventions

The impacts of the interventions were:

- A. The speeds decreased from 43 km/hr to 11 km/hr with the initial raised zebra crossing slope and to 16 km/hr after making the slope gentler.
- B. Obstruction of pedestrian movement by street traders was minimal and vehicle parking on the walkway eliminated. Pedestrians no longer had to walk on the carriageway.

- C. Traffic safety was generally much better at/near this spot. No accidents were reported after implementation of the intervention. The attractiveness of the pedestrian short cut route had increased.
- D. The walkway pavement remained in good condition, including on the walkways with compacted earth.
- E. Slowing down cyclists with the raised zebra crossing was also useful. It almost eliminated unpleasant, although not the very dangerous conflicts between speeding bicycles and pedestrians. Prior to the interventions, bicycle speeds of up to 30 km/hr were common.
- F. After this second round of interventions, the route functioned very satisfactorily. The pedestrians could now cross safely and move on the walkways, without being forced to mix with the motor vehicle and bicycle traffic on the main carriageway.

8.3 Walkway Improvements along a Road Corridor, Morogoro

Background

Speed, convenience and safety of walking, along urban streets in SSA, are very much influenced by the difficulties created by obstructions and the lack of pedestrian infrastructure facilities. Typical examples of difficult spots are areas where buses and taxis park or stop, fuel station entrances, open drains forcing pedestrians to walk on the carriageway and generally the lack of dedicated walkways.

In most instances, walking could be improved significantly by taking care of the problem spots. Often, except for treating the obstacle spots, there is no need for a more expensive upgrading of the entire route.

Conditions Prior to Interventions

The conditions prior to the interventions were:

- A. This road is a very important pedestrian route in Morogoro and connects the residential areas in the east to the CBD. The pedestrian ADT increases as the road gets nearer to the center. Pedestrian ADT, at the CBD, was around 10,000.
- B. Existing soil is of reasonable quality. When designed properly and not damaged by parked vehicles, a compacted soil footpath remains accessible during rains.
- C. The vehicular traffic on the main carriageway was a mixture of motor vehicles (± 40 percent of all vehicles) and cyclists (± 60 percent of all vehicles).
- D. The bitumen carriageway was 8 to 10 meters wide and of fair pavement quality, (some isolated potholes were filled with gravel).

Problems

Some of the problems encountered were:

- A. Pedestrians had to walk through several dangerous spots on the carriageway, in particular where two small streams passed under the road in big culverts (see Figure 8.2 below).
- B. Pedestrians had to criss-cross their way into the regional hospital because the entrance was usually blocked by chaotic minibus and taxi parking.
- C. There was a dangerously long crossing distance (± 20 meters), created by a badly designed fuel station entrance at a Y-junction.
- D. MV speeds were too high (>50 km/hr) for the prevailing traffic conditions.

Objective of Interventions

The primary objective of the interventions was to create a safe and convenient walking route along this road.

Interventions

The walkway was 900 meters long and the improvement package included:

- A. The construction of a separate walkway along the regional hospital fence, separated from the parked taxi and minibuses (pavement: compacted murrum; low masonry walls around flower beds were used as part of the separation);
- B. Reconstruction of the walkway in front of a fuel station and reconstruction of an adjoining Y- junction to T-shape;
- C. Construction of three traffic calming spots to improve crossing safety (narrowing with bicycle slips at two intersections and speed bumps in front of the hospital);
- D. Construction of four pedestrian bridges over small streams (or open drains); and
- E. Small spot improvements to walkway pavement (compact murrum).

Cost of Interventions

The total cost of the above interventions was US\$ 18,000.

Figure 8-2. Location of the different improvements

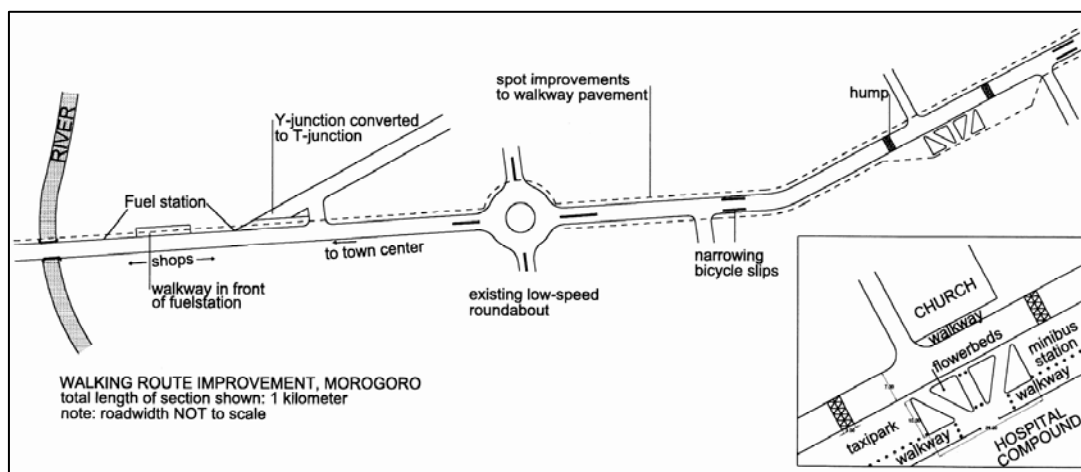

Impacts of Interventions

The impacts of the interventions were:

- A. The pedestrians as well as the other road users considered the walkway improvements to be very convenient and user friendly. “Fine-tuning” of the initial improvements further increased the public appreciation of the intervention because the fine-tuning upgraded the entire route. This was done mainly to resolve the remaining bottlenecks (with spot repair of pavement, protective concrete bollards at the reshaped junction, and walkway re-alignment). The observed travel (walking) time reduction after improvement was 4 minutes per kilometer.
- B. The total cost was US\$18,000. US\$12,000 were used for the pedestrian bridges on both sides of the road over two small streams and for the repair of the existing culverts. Total annual cost of the improvements was US\$4,200 (capital investment US\$2,400 annual walkway pavement maintenance US\$1,800). Prior to the interventions, the absence of pedestrian crossings over the streams at two intersections seriously reduced intersection capacity since pedestrians used the carriageway and faced the associated high accident risk. Total annual benefit was US\$14,400 (estimated average time gain of 4 minutes/km with pedestrian ADT of 8,000, excluding the benefits due to reduction of accidents). This results in a B/C ratio of 3.4, based on increased walking speed alone.



Photo 8-3-1. Entrance to the regional hospital, after the improvements



Photo 8-3-2. Walkway along the hospital fence, separated from taxis and minibus



Photo 8-3-3. Walkway separated from the carriageway at the fuel station entrance



Photo 8-3-4. Pedestrians only bridge over a side drain at an intersection

8.4 Pedestrian Route Improvement, Temeke

Background

The old part of Temeke (Ward 14) is a planned area, 8 kilometers from the central business district. It was developed in the 1960s, as a mixed residential and commercial area. Since the 1970s, there has not been any construction of new roads and road maintenance has been very poor. In addition, as the economy declined, unplanned residential development grew rapidly. In the mid-1990s, this area grew to a high population density, despite the fact that almost all the houses are ground floor only.

Since 1997, the government has tried to revive the economy of the area with several schemes. At the time of the pilot project implementation, the central part of Temeke was undergoing a significant change. A large market had been constructed (a 20,000 square meter walled compound). It was built with the expectation that it would bring back more businesses as well as more customers.

Due to these developments, the requirement to have safe and direct pedestrian routes for the main travel flows (walking trips) inside Temeke gained in importance. At the same time, proper traffic calming was required to assure pedestrian safety because the motor vehicles would also increase. Planned parking facilities would also become more important in order to prevent random parking, creating traffic chaos. Finally, a greater “secondary CBD” function in Temeke would increase the number of relatively short distance trips within the area. These short trips are ideally suited for cycling, which costs less and is faster than both the minibus and walking.

Conditions Prior to Interventions

The conditions prior to the interventions were:

- A. The people living in the area and those with businesses had both parallel and conflicting interests. Those who illegally occupied part of the road reserve with their businesses and obstructed NMT, could easily see a municipal initiative to upgrade the walking routes as a threat, because the walkways required the public land, which they now used as their own. Other businesses, which depend on being accessible for their customers, most of them pedestrians, welcomed improving the walking routes.
- B. Construction of pedestrian walkway facilities in the area was not advisable without concurrent drainage re-construction.
- C. Construction of pedestrian walkways would not be durable unless the pavement of the vehicle access roads was also improved to at least gravel standard. Failure to do so would make pedestrian facilities so superior to motor vehicle facilities that it would not be possible to stop vehicles from using them for driv-

ing or parking and quickly destroy them in the process. Bollards or any other obstacles would not be effective in preventing the motor vehicles use of the walkways. It is also likely, as experience showed in earlier tests with interventions that these interventions would be taken away because they would be highly contested by some vehicles owners.

Problems

Some of the problems encountered were:

- A. The high density of residents, combined with the high number of commercial customers, made it highly undesirable for the roads to attract a significant amount of transit traffic. Transit traffic had to stay on the surrounding urban corridors: Nyerere Road, Mandela Road and Kilwa Road.
- B. The trucks parked on the road shoulders at night.
- C. Traffic flow was unsafe at many key intersections.
- D. The main pedestrian routes in the area did not follow the collector roads, but cross them at right angles towards the central part of the ward, or the adjacent industrial area outside the ward, or to bus stops along the collectors. Many routes had no official rights of way or pavements. All access roads in Temeke were in bad condition. Motorized traffic and erosion had transformed the remaining roads into a sandy desert, with pools of stagnant water during the rainy days.
- E. Drainage was quite bad in most parts of Temeke. The main reasons were:
 - i. Most of the soil was bare, the drains quickly silted with sand due to heavy erosion;
 - ii. The drains are hardly maintained; and
 - iii. The drains were partly destroyed by trucks parking on drain walls.

Objectives of Interventions

The objectives were:

- A. To create safe, direct and comfortable access on foot or bicycle to the CBD of Temeke and to the new market and its surrounding area from all residential parts of the ward. The proposed pedestrian network would be part of a larger plan, which would provide for:
 - i. efficient motor vehicle circulation on the collector roads in the area,
 - ii. minibus routes/stops on the collector roads only,

- iii. a pedestrianized core access network to the market from three sides, with a minimum number of crossing points with MT roads,
 - iv. good motor vehicle access to the market for freight traffic (supplies) and businesses in the central area,
 - v. designated parking lots for vehicles and
 - vi. prevent parking along the collector roads in the central area.
- B. These interventions would demonstrate that a good NMT route, from the unplanned area to the CBD, could be constructed at modest costs and significantly improves the mobility of residents.

Interventions

This intervention primarily consisted of the construction of a pedestrian walkway towards a newly constructed market, approximately 500 meter long. Part of the track was paved with concrete slabs and part of it with compacted gravel. The track alignment was partly without motor vehicle crossing; for that purpose, one access road along the market was converted into a dead-end road on one side and a circular access loop on the other side (see Figure 8.3). As a result, bus transit traffic on this road was no longer possible. Simultaneously, as part of the test intervention, drains were constructed and the carriageway improved to gravel standard.

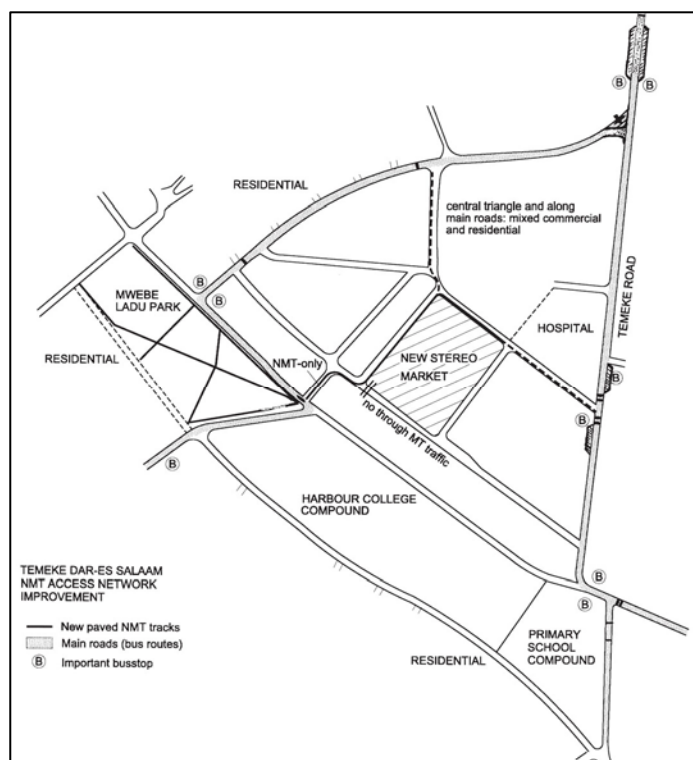

Figure 8-3. The new market and the improved walking routes

Cost of Interventions

Total cost of the above intervention was US\$70,000.

Of this total amount, US\$15,000 was for walkways, US\$19,000 for carriageway reconstruction, and US\$38,000 for the drains. The most costly item was the drainage system. Without good drains, the usefulness of the walkways and the market area would be minimal during the rainy season. Furthermore, erosion due to lack of drains would easily and quickly destroy the walkways. Without proper drainage, these improvements would be short-lived. Compared to the cost of the drains, walkway cost was much less. Unit costs were:

- A. Walkway + motor vehicle blocking: US\$5-12 /m², and
- B. Stone masonry drainage system: US\$40-70 /m length.

Total annual cost of the investment, including the required periodic maintenance was US\$12,000. Of this, US\$3,000 was for the walkway (\pm 500 m), including annual walkway pavement maintenance of US\$1,000 (US\$0.5/m²).

Impact of Interventions

The impacts of the interventions were:

- A. The immediate effect was a very positive response from the road users. This response was reinforced by the fact that walkways, drains and carriageway improvements were combined, which benefited all road users.
- B. Immediately after the opening of the new walkways, the pedestrian ADT at different spots varied from 1,000 to 4,000. However, this could increase substantially as the new market attracted more customers.
- C. The average travel time gain by pedestrians, using the new walkway, was estimated at four minutes per kilometer. This means that a pedestrian ADT of 1,000 would result in travel time benefit of US\$2,000 per year. The estimated pedestrian break-even traffic for this walking route (4-meter wide walkway) based on this is shown in Table 8.2 below.

Table 8-2. Break-even pedestrian ADT for walkway investments

Existing pavement condition	Proposed pavement	Pedestrian ADT Required for B/C = 1.0
Not paved, bad or no maintenance	Well compacted murrum	2,600
Not paved, bad or no maintenance	Concrete slab pavement	3,200

- D. The estimated maximum peak walkway capacity, of a 4-meter-wide walkway with two-way walking and some disturbance by street trading, is 2,000 persons per hour. This corresponds to an estimated maximum ADT of 12 to 15,000 per track, which was compatible with approximately 20,000 daily visitors to the market area after the market was fully developed.

8.4



Photo 8-4-1. Part of the route before intervention



Photo 8-4-3. Part of the route before intervention



Photo 8-4-2. Same route after intervention



Photo 8-4-4. Same route after intervention

8.5 Yombo River NMT Bridge, Temeke

Background

The implementation of this improvement took almost two years. The intervention was not technically complex. The primary reason was that this intervention was designated by the PPU as a 100 percent user participation case.



Photo 8.5-1. Meeting of the Yombo River bridge user platform

The agreements stated that there would be a significant contribution from the local community, financially or through labor, towards the cost of the bridge and in addition, the community would take care of its maintenance. During the construction period, the LUP volunteered to store the cement bags in one of their member's houses. They counted the bags when they were brought, guarded them at night, registered them when they were taken out and monitored how they were used on site. The bridge was constructed successfully, with labor contributions from the community.

During the first rainy period after construction, the bridge functioned quite well. However, in October 1997 extremely heavy rains, nicknamed “el-Niño rains”, washed away a large number of road bridges in Tanzania and Kenya. These rains damaged one of the ramps to the bridge. The required repair was an unexpected early test of the maintenance commitment of the community. The PPU was willing to pay for the cost of the materials required to repair the damage (\pm 50% of the total costs), if the community was willing to do the work without pay.

Temeke has several unplanned parts, due to a very rapid population growth and lack of development controls. Most of these areas have major accessibility problems. The direct NMT route, towards the center of the Temeke ward (schools, markets, jobs, bus station), had to cross the Yombo River, without a bridge. Since the direct benefits of the NMT Bridge were obvious to the local community, they established a specific user platform (UP) with clear terms of reference, in cooperation with the PPU. The LUP short-listed the construction of the Yombo River NMT Bridge.



Photo 8.5-2. Damaged bridge after heavy rains



Photo 8.5-3. Repaired Yombo River bridge after heavy rains



Photo 8.5-4. Yombo River bridge after the repairs

During the dry period after the damage, a long period of “struggle” ensued. The community implicitly decided to test whether if they refused to do their part, the PPU would, repair the bridge on its own. After six months, the community realized that the PPU would not repair the bridge without their participation. Then the community agreed to contribute the labor and Dar es Salaam City Council (DCC) contributed the required materials and supervision. The bridge was repaired and the general quality of the work was quite satisfactory.

Conditions Prior to Interventions

The conditions prior to the interventions were:

- A. Yombo River is a small river with sandy soil and considerable erosion.
- B. The area is populated with low to middle-income households.
- C. During the initial period of plan preparation, there was a request from the top decision-makers to construct a NMT/MT bridge, partly because there was no precedent to building a NMT only bridge. Subsequently, after much discussion, decision-makers supported the NMT only bridge concept.
- D. Prior to the construction of this bridge, the pedestrian ADT over the bridge was about 1,300 and in the rainy season it would be reduced by 50 percent depending upon the water level in the river.

Problems

The main problem was the lack of direct NMT access (pedestrians, cyclists and carts) from the unplanned areas to the markets, schools, hospitals and bus routes.

Objectives of Interventions

The primary objective was to create a direct NMT route between Yombo Island and the central part of Temeke.

Interventions

The river is totally dry during the dry season but impassable during the rainy season. A two meter-wide, NMT only bridge was constructed. It is a culvert type bridge, designed to provide erosion protection by gabions.

Cost of Interventions

Total cost of the bridge was US\$11,000, including the cost of labor contributed by the community (computed equivalent cost) for the original construction plus later repairs after the very heavy rains (mainly riverbed protection with gabions). Annual cost of capital and maintenance was US\$1,500.

Impact of Interventions

The impacts of the bridge were:

- A. The bridge provided a good and direct NMT access route to various daily activities such as schools, markets, work centers and medical facilities. There were bottlenecks like before, but the bridge was highly appreciated by the users.
- B. Subsequent to the completion of the bridge, micro-commercial activity was starting to develop along the route. The pedestrian volume, after the opening of the bridge, went up by ± 50 percent and it was expected to increase further. Bicycles traffic was about ± 100 per day and ± 50 small pushcarts started to use this route daily.
- C. The local community and the LUP show a great deal of pride in this achievement.
- D. After the construction of the bridge, pedestrian (95 percent) plus cycle (5 percent) ADT was about $\pm 2,000$. The estimated average pedestrian travel time gain per trip was 5 minutes (average over existing and diverted trips during the dry and wet seasons). The travel time gain for existing traffic from easier passage at the bridge location was around 1 minute during the dry season and 2 minutes in the wet season. For the others, the detour via the nearest dry crossing (a railway bridge) required 15 to 20 minutes. The estimated corresponding value of the travel time gain was \pm US\$6,000 per year. The estimated B/C ratio of this intervention was 4.0.

8.6 Sosiani River NMT Bridge, Eldoret

Background

During the mid-1970s to early 1990s, a new low-income area south of the town center grew into a large population. The Sosiani River, by creating long detours, was a major obstacle for pedestrian trips to the CBD. In the early 1990s, a club of high-income Eldoret citizens paid for the construction of a 1.5-meter wide footbridge over the main riverbed, as a gift. The bridge improved the usefulness of the route substantially. However, during the rainy season the route continued to be difficult to use or impassable because of the very bad condition of the tracks on both sides towards the river and the water in the flood plain. Hence, the bridge could be used only when the water level in the river was very low.

Constructing a proper NMT route, at a spot like this, involved significant costs. The Eldoret Transport Committee, a group of stakeholders representing a wide range of groups in Eldoret, selected this intervention as a priority, in spite of the costs. Sosiani Bridge is the shortest route from this area to the CBD. Figure 8.4 below shows the details.

Figure 8-4. Route network: routes and the river

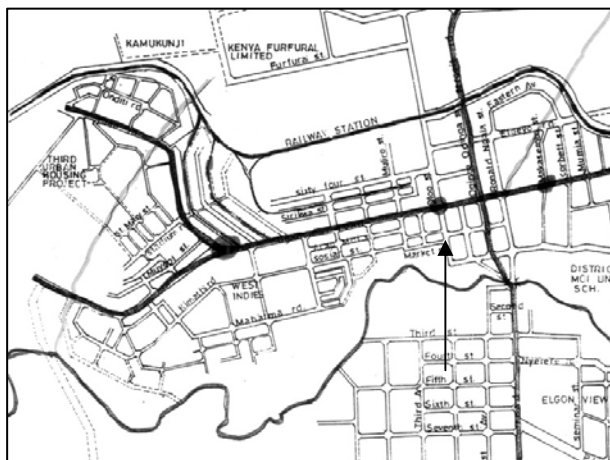

Conditions Prior to the Interventions

Some of the conditions prior to the intervention were:

- A. The river bed is 60 meters wide, a flood plain with stable river banks and stable soil of 1.5 to 2.0 meters depth for bridge foundations; and
- B. There was no official right of way (public road reserve) for most of this route, which had originally developed randomly, without any official approval.

Problems

Some of the problems encountered were:

- A. Existing route frequently impassable during the rainy season;
- B. Pedestrian walking speed was an average of only 2.5 km/hr, for crossing the flood-plain and the highly polluted connection towards the town center; and
- C. The pavement was in very bad condition.

Objectives of Interventions

The objectives were:

- A. To create a good, direct all-weather NMT route from the south towards the town center which could be used by pedestrians and cyclists; and
- B. To establish a legal right of way for the route in order to prevent any future landowners or squatters from constructing fences, houses or other buildings which trespass the right of way.

Interventions

The interventions consisted of the following measures:

- A. To construct of a new low level, concrete pedestrian bridge over the summer bed of the river with a reinforced concrete deck;
- B. To add another 1.5 meter wide steel bridge (\pm 20 meter long), to avoid congestion at the bridge, over the permanent part of the river;
- C. To establish a road reserve for the route north of the river to the CBD;
- D. To build a paved NMT track to the CBD on the above road reserve; and
- E. To Improve the NMT track, towards the residential area.

Cost of Interventions

The total cost of the interventions (300 meters NMT track and bridge) was US\$43,000. Total annual costs including maintenance cost was US\$7,100.

Impact of Interventions

The impacts of the interventions were:

- A. The opening of the new “Sosiani causeway” NMT route was widely appreciated, by its users as well as by Eldoret inhabitants in general. Often, the decision-makers tended to think that such a high investment in an NMT route would not be a wise one. However, this intervention had a very positive impact on

public opinion, which was already in favor of the investment for dedicated NMT facilities such as NMT only routes, walkways, short cuts and bicycle tracks.

- B. The improved attractiveness of the route had started to influence the land use along the route, particularly in the areas near the CBD. Therefore, it will be necessary to protect the route from encroachment by kiosks and street traders. This could be done by creating an open area of at least two meters wide between the front of kiosks and the paved walkway.
- C. The impacts on pedestrian and of bicycle traffic volumes were a bit complex to assess because major improvements were being made at the same time to an alternative river crossing route, which was partly serving the same trip origins and destinations (Bridge on Kisumu Road). As a result, the pedestrian volume on the improved Sosiani Bridge decreased from an initial 6,500/day to 5,500/day. The changes in mode and route choice patterns were analyzed by means of roadside interviews. This showed that:
 - i. On both routes, the combined bicycle traffic increased by 500 cyclists per day, one-way, representing an over 30 percent increase of the existing volume of cyclists; and
 - ii. The combined pedestrian traffic increased by around 300 per trips day (one-way), representing an increase of 3 percent.
- D. The components leading to the pedestrian flow changes were:
 - i. A significant change in route choice of pedestrians back to Kisumu Road, particularly by the people who had previously made the difficult detours along the Sosiani causeway to avoid the dangerous Kisumu Road bridge;
 - ii. A small decrease in the total number of pedestrians due to a modal change from walk-to-bicycle; and
 - iii. A larger increase in pedestrian traffic, due to a modal change from bus-to-walk.
- E. The shift from walk to bicycle as well as the shift from bus to walk was partly triggered by improved traffic safety. The largest part of the modal shift towards cycling came from former cyclists who had previously shifted to the bus for fear of traffic accidents.
- F. Pedestrians who had given up cycling out of fear of traffic accidents, but still have a bicycle, now returned to cycling. People who took a bus, to avoid walking the dangerous road section over the Kisumu Road Bridge, returned to walking.
- G. A new traffic count on both routes, one year after the interventions, indicated that half of the initial modal shift to cycling faded. The new cyclists on the

NMT-only route remained, but those on Kisumu Road again disappeared. The renewed reduction in cyclists on Kisumu Road was due to the fact this route still has a number of dangerous spots. Solving one dangerous spot does not make the entire route safe. The improvements have to be over the entire route or the entire system.

- H. The initial optimism of those who resumed cycling probably faded with the renewed experience of unsafe traffic conditions along the other parts of the route. This is the same trend in Eldoret as a whole. Bicycle ownership in Eldoret is high, with more than 50 percent of all households having one or more bicycles. Cycling used to be important. However, the current modal share is still around 10 percent of all daily trips, but it could continue to slowly decrease if the trend of increased traffic accidents continues.
- I. The estimated benefits were:
 - i. The pedestrian ADT was approximately 6,000 and growing over time. The travel time gain for pedestrians was three minutes in the dry season and eight minutes in the rainy season. This corresponds to a benefit of US\$15,000 per year.
 - ii. Bicycle ADT went up from 100 to 400. Part of this increase was a shift from walk to bicycle and the remaining from minibus to bicycle. There was a small amount of diverted bicycle traffic.
 - iii. For existing bicycle trips, the benefit of the route improvement was 1.5 US¢ per trip. For a modal shift from minibus to bicycle, the estimated cost saving was US¢23 per day (round-trip), and for a modal shift from walk to bicycle the estimated net cost saving was 1.5 US¢ per passenger km, or ± US¢12 per day (increase in direct costs, larger decrease of time costs).⁷⁰ Estimated total saving for the current bicycle traffic was US\$14,000 per year.
 - iv. The increased land value along the city-side part of the track due to its attractiveness for street vendors, was estimated at US\$2,000/year.
 - v. To avoid double counting, the reduced traffic accidents during the rainy season (previously Kisumu Road had to be used as a detour), were not included in computing the B/C ratio.
 - vi. The estimated B/C ratio was 4.4, which is high. It indicates that the benefits over a period of only one and a half years equal the entire investment. This is an example that shows that it can be a sound economic policy to invest in selected direct and safe NMT-only routes on newly established road reserves, unrelated to the existing road network.

⁷⁰ Economic Justification of Investments in Urban NMT Infrastructure, Tanzania National NMT Seminar, Dar es Salaam, December 1998.



Photo 8-6-1. The route towards the CBD, before improvement

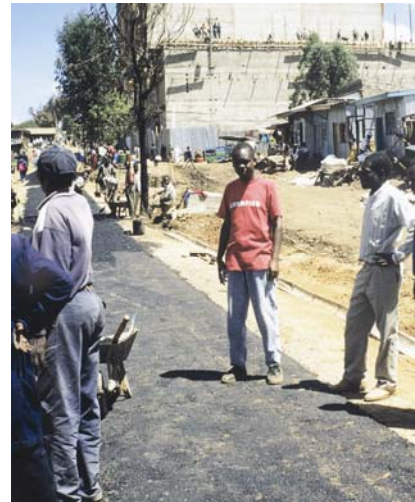

Photo 8-6-2. The route towards the CBD, after improvement

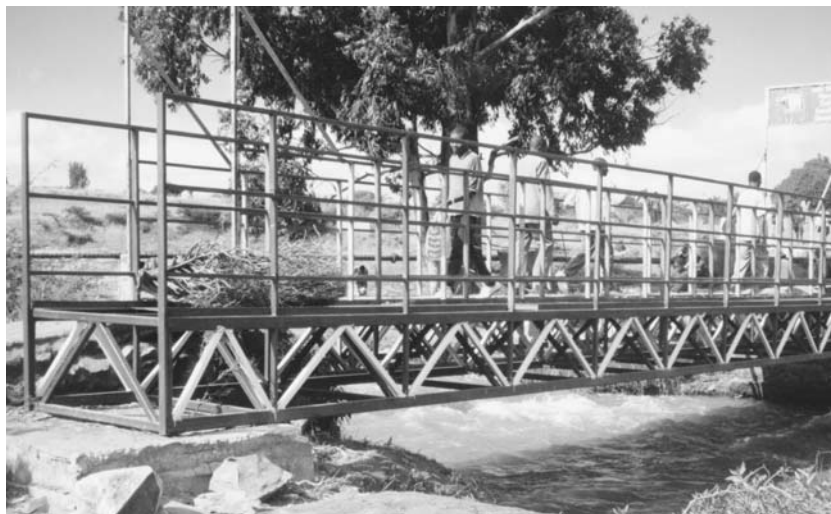

Photo 8-6-3. New steel bridge over the Sosiani River

8.7 Raised Zebra Crossings on Temeke Road, DSM

Background

At the time of the pilot project interventions, raised zebra crossings were unknown in Tanzania. There is a much greater variety of vehicles in Tanzania than in either Europe or the United States. The bottom clearance, in a significant number of vehicles, is less than it should be according to the vehicle specifications, probably because of failing suspensions or overloading. Therefore, major road bumps could cause serious damage to many vehicles, especially if these

vehicles travel faster than they should. Flattop bumps (a raised zebra crossing is a flattop bump) create much less damage to these vehicles than the regular road bumps. The raised zebra crossings should be designed to slow down the motor vehicles but not to damage to them.

Conditions Prior to Interventions

Some of the conditions prior to the interventions were:

- A. A large number of pedestrians crossed this road. For example, the estimated pedestrian ADT on Mahunda Street near the intersection of Temeke Road was 10,000. The average pedestrian ADT crossing Temeke Road at the locations where the raised zebra crossings were constructed was approximately 2,200. The concentration of pedestrians was the highest at junctions with side streets but the activities along this road section were so dispersed that pedestrians crossed the street everywhere.
- B. During the day, motorized traffic varied between 500 and 1,000 vehicles per hour (two-way). Most of these vehicles are minibuses (Dala Dala) which carried an estimated 15,000 passengers/hour in each direction on Temeke Road.
- C. Dala Dalas stop randomly anywhere on the road shoulder, to load and unload passengers.
- D. The estimated ADT of cyclists was 1,000-1,400 on Temeke Road and \pm 2,300 on Mahunda Street.

Problems

Some of the problems encountered were:

- A. Crossing the road was dangerous for pedestrians, due to the high speed of motor vehicles combined with the unwillingness of most drivers to slow down to let pedestrians cross.
- B. Due to the high speed of vehicles, cycling in mixed traffic was dangerous. Furthermore, the speed increased the risk of vehicle/vehicle collisions.

Objectives of Interventions

The objectives were:

- A. To create a calmed down traffic flow along the entire section of Temeke Road, allowing safe pedestrian crossings at most points along the road; and
- B. To create some crossing points with low motor vehicle speed, where vulnerable pedestrians (elderly, children, and the disabled) could be assured that, they would always be able to cross without danger (create “green spots”).

Interventions

The intervention consisted of constructing 10 zebra crossings on Temeke Road. Figure 8.5 shows the design. In most cases, the slopes were made of pre-cast concrete blocks, the top pavement with bricks. Painted steel bollards, generally > 80 cm high, provided the necessary visibility and a row of T-blocks stopped vehicle access to the walkway near the crossing points.

Figure 8-5. Design of a raised zebra crossing

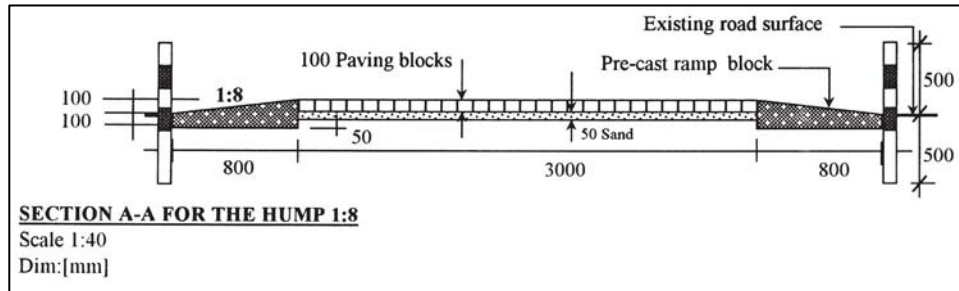

Cost of Improvements

Typical cost of a single raised zebra crossing, constructed on an existing road, was about US\$4,500 including accompanying measures. The corresponding annual cost was US\$1,000, including maintenance costs.

Impact of Interventions

The impacts of the interventions were:

- A. Different slopes and heights were used in the design of the raised zebra crossings, to enable an understanding of the impact on vehicle speed reductions, under different conditions. The raised zebra crossings, which are flat top bumps, are less hazardous to vehicles than the regular speed bumps. This factor is especially important in view of the much varied vehicle size, shape and conditions in Tanzania, compared to Europe or the United States. The raised zebra crossings, previously unknown in Tanzania, were welcomed as a better alternative to the speed bumps and were used later in other locally initiated projects.
- B. An unexpected positive effect was the concentration of Dala Dala stops at the new bus bays adjacent to the raised zebras, rather than at any location.
- C. Positive impacts for motorized traffic were:
 - i. Reduced cost of accident damage and no significant increase in average speed on this road section, and

- ii. The unchanged average speed due to the combined effect of lower maximum speeds (-), reduced intersection-waiting times (+), and less delay caused by random minibus stops (+).
- D. The raised zebra crossings are difficult obstacles for large carts, although easier than road bumps of similar height. Their systematic introduction on all local and collector roads could conceivably make the operation of large pushcarts so difficult that the operators would have to change to smaller carts, which could be operated on pedestrian walkways. From a traffic circulation point of view, this can be regarded as a positive effect.
- E. The pedestrian waiting times at the raised zebra crossings increased. This was due to two factors:
 - i. Slowing down the vehicles does not influence the size and distribution of the vehicle gaps, nor increase the willingness of the drivers to yield to pedestrians; and
 - ii. Traffic calming of an entire road section leads to more dispersed pedestrian crossings, reducing the overall pedestrian/motor vehicle interference and the corresponding delays.
- F. A greater percentage of the more vulnerable pedestrians waited at the raised zebra crossings, for longer vehicle gaps before crossing.
- G. Interviews with road users confirmed that most people felt safer and at ease after the traffic calming interventions. On raised zebra crossings, vehicles pushed through as much as they could and pedestrian waiting time did not go down.
- H. The driver behavior at a bump seems to be more uniform in Tanzania than it is in Europe, probably due to the higher importance attached to vehicle damage. This seems to apply equally to drivers of private and public transport vehicles. While the latter seem to drive rather recklessly at some points, one will not see them drive fast over a raised zebra crossing or speed bump.
- I. The visibility of the raised zebra crossing is very important. Painted white stripes result in little improvement in traffic calming, due to sand and dust accumulating on the road surface and to quick wear and tear of the paint. The legally required traffic signs also did not help much to improve the visibility of a raised zebra. The most effective elements were:
 - i. High vertical iron pipe bollards (> 80 cm), painted with black and white stripes,
 - ii. White painted T-blocks to protect the pedestrian waiting area from vehicles which might attempt to bypass the raised zebra crossing over the road shoulder, and
 - iii. Pre-cast concrete sloping blocks painted with black and yellow triangles.

- J. Uniformity of design, throughout the entire city, was also important to achieve easier recognition by the drivers.
- K. Traffic accidents, on the road sections where the raised zebra crossings were systematically constructed, were almost eliminated. Safe crossing became possible and bicycle safety improved significantly.

There were substantial benefits due to the reduction in accidents. Five raised zebra crossings were constructed at the first test section along a part (40 percent) of Temeke Road. During the six months prior to the intervention, 12 accidents occurred there (with three hospitalized victims). No fatal accidents occurred although there were five fatal accidents during the previous year! In the six months after the interventions, the number of accidents decreased to two, with only one hospitalized victim.



Photo 8.7-1. RZC on a collector road with a pedestrian area protected by T-blocks



Photo 8.7-2. Children crossing over a RZC



Photo 8.7-3. Minibuses always drive slowly over the RZC



Photo 8.7-4. Vehicles moving slowly to pass over a RZC

8.8 Speed Bumps on Nile Road, Nairobi

Background

This initiative came from the teachers of one of the schools. In many countries, the reduced speed limits at school zones, are part of the traffic laws and design requirements. There is no such legal provision in Kenya and traffic law enforcement is very lax. The traffic conditions were too dangerous to young students and accidents had occurred.

Nile road is also a busy minibus route. After the negative test results with painted zebra crossings in Nairobi, the PPU decided to try the speed bumps.

Conditions Prior to Interventions

Some of the conditions prior to the interventions were:

- A. Nile Road had fair bitumen road surface with a wide straight road section and it passed several schools.
- B. It is not an arterial road and therefore there were no objections to speed bumps.
- C. ADT for motor vehicles was 3,100.
- D. Average number of pedestrians crossing, in front of one of the schools, was 830/day (620 children and 210 adults), with similar numbers near the other schools.

Problems

Some of the problems encountered were:

- A. This collector road passes through the location of two primary schools. The road width (7-8 meters), the good pavement quality and the absence of nearby intersections invited very high speeds. The highest measured speed was 105 km/hr and 62 km/hr for the average speed.
- B. Average number of accidents, near the schools, over the four years before the intervention were: fatal 0.75, serious injury 2.25, slight injury 6.5.

Objectives of Interventions

The primary objective was to create safe traffic conditions for pedestrians, particularly for primary school children crossing the road. This would require reducing the speeds to 15-20 km/hr at school crossings.

Interventions

Three round shaped speed bumps were constructed on Nile Road. These asphalt concrete bumps were 10 centimeter-high with a slope of 1:10. Figure 8.6 below, shows the design of the bumps.

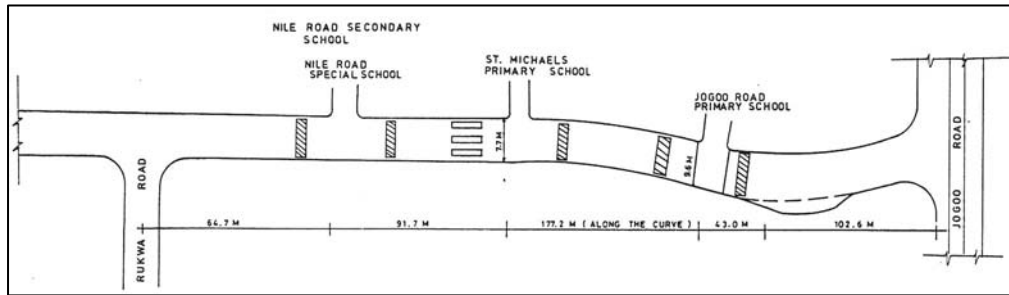

Figure 8-6. Design of speed bumps on Nile road (not to scale).

Cost of Interventions

Cost implementing five road bumps was US\$2,400. Annual cost of capital and maintenance was US\$510.

Impact of Interventions

The impacts of the interventions were:

- A. To reduce speed from an average of 62 km/hr before the interventions to an average of 20 km/hr, in-between the bumps and the target was achieved.
- B. During a one-year observation period after construction of the bumps, no dangerous traffic conflicts were observed and no serious accidents reported.
- C. Reactions of the pedestrians were very positive (general users, children, parents and teachers). Initial reactions of drivers were mainly negative but they disappeared over time.
- D. The travel time by car over the 300 meter-stretch with the bumps, increased by 18 seconds. The average transit speed after the intervention, of 26 km per hour, was still significantly above the Nairobi network overall average.
- E. There was no impact on road capacity. The determining capacity bottleneck was the intersection at Jogoo Road.
- F. There was no impact on vehicle route choice.

- G. The conclusion was that the reduction of speeds to 20 km/hour would reduce serious traffic accidents. There were no reports of serious accidents caused by high speed of drivers surprised by the presence of the bumps.
- H. Reliable accident data are not available. Available police records and anecdotal evidence by teachers indicated that the number of prevented injuries was significantly higher.



Photo 8.8-1. Two round top speed bumps at a short distance creating a safe crossing spot in DSM, similar to the ones on Nile Road



Photo 8.8-2. Example of pre-fabricated speed bump

8.9 Pedestrian Crossing Islands, Temeke

Background

The request to construct safer pedestrian crossing facilities along Temeke Road was formulated by the LUP for this location. The frequent occurrence of accidents involving pedestrians was the primary reason for this request. Many schoolchildren cross the road here. The initial request was for raised zebra crossings, similar to the ones constructed on another section of Temeke Road. However, after further consultations, the NMT project team proposed to construct pedestrian crossing islands.

Pedestrian crossing islands have two advantages and one disadvantage over the raised zebra crossings:

- A. They allow independent crossing in both the traffic directions, thereby require a smaller inter-vehicle gap. Consequently, they reduce the waiting time, provide a safe crossing opportunity and provide physical protection while waiting on the refuge island;
- B. They cause less discomfort to vehicles (no bumping).
- C. The speed reduction created by an island is usually much smaller than that created by a raised zebra crossing or speed bump.

After further consideration, an additional speed bump was constructed to discourage the remaining small number of fast drivers from speeding.

Conditions Prior to Interventions

Some of the conditions prior to the interventions were:

- A. The bitumen pavement on Nile road was of only fair quality.
- B. ADT for the vehicles was well below the maximum road capacity. The highest observed total was ± 500 vehicles/hr. As a result, vehicle speeds were often quite high, with an average of 44 km/hr and the average of the 10 percent highest speeds was 60 km/hr. Most traffic was through traffic, with no significant trip destinations or origins in the neighborhood.
- C. Ten percent of the vehicles on the road were bicycles. ± 75 percent of all persons moving along this road traveled in minibuses.
- D. The number of pedestrians crossing the road, where the crossing islands were constructed, was 4,000 - 5,000 per day.

Problems

Some of the problems encountered were:

- A. Road crossing conditions for pedestrians were quite unsafe. The lack of safety was due to two factors: high vehicle speed (relative to the type of road and roadside activities) and completely open and undefined road shoulders. This increased the crossing distance of 9 meters, exposing those walking along the road to the sudden maneuvers of vehicles. In addition, at some points pedestrians were forced to walk on carriageway where the shoulders were blocked by parked vehicles.
- B. The traffic behavior of both drivers and pedestrians was unsafe. Drivers often misjudged their speed, braking distances and maneuvering skills, with the result that hitting static objects along the road was remarkably frequent (bollards, electricity poles). A significant number of pedestrians daringly crossed the road taking undue risks dangerously.

Objectives of Interventions

The objectives were to:

- A. Provide safe pedestrian crossing facilities
- B. Slow down the speed to around 40 km/hr by means of carriageway deflection around the islands, without causing discomfort; and

- C. Increase the safety of cycling, by reducing speed.

Interventions

Four traffic islands were constructed on a 350 meter long road section, three of them with a pedestrian crossing and one as a traffic separator at a T-junction. The islands were 2.0 meter wide and 12-15 meters long, with high curbs and further strengthened with T-blocks. At the edge of the road, a shoulder/carrigeway separation, with curbs, was constructed. However, in similar cases, the shoulder separation would be better with T-blocks. The typical design of the pedestrian island is shown in Figure 8.7 below.

Figure 8-7. Typical design of pedestrian crossing islands

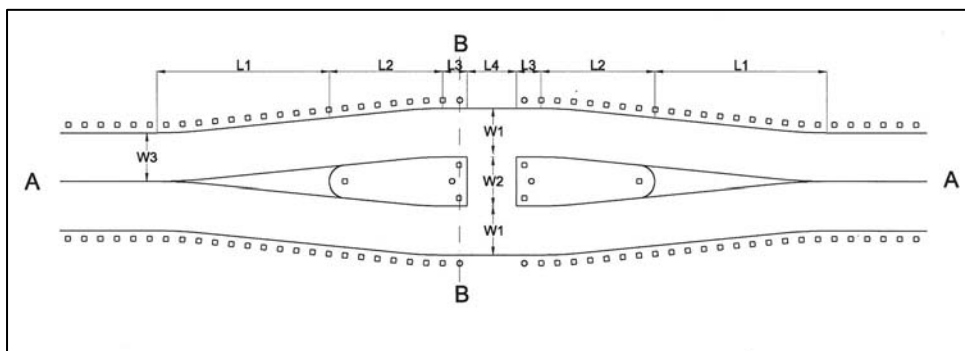

Cost of Interventions

The construction costs per island were \pm US\$3,300. The annual cost, including capital and maintenance costs, of a new traffic island on an existing road was approximately US\$1,200.

Approximately 25 percent of the capital cost was for the island itself (constructed with high curbs), 50 percent for the carriageway alignment at the road shoulder (constructed with curbs although T-blocks were less expensive), and 25 percent for other items. The construction costs on an existing road depend on the carriageway width, which determines the required amount of extra carriageway around the island.

Impact of Interventions

Several effects of the pedestrian crossing islands were observed:

- A. The average pedestrian waiting time at the road shoulder, before crossing to the island, was approximately equal to the average waiting time on the island before crossing to the other side of the road. This showed that pedestrians cross the two opposing vehicle flows independently.

- B. The islands imposed motor vehicle lane discipline and reduced the potential to overtake, creating a more quiet traffic pattern. Unfortunately, as a result, many pedestrians did not bother to make the small detour required to cross exactly over the islands, but crossed in-between, with a waiting pause in the middle of the road if needed or in the “shadow” of the island. Pedestrians’ habit of waiting in the middle did not exist previously since it was considered too dangerous to do so.
- C. It is uncertain whether the perception that it was safe to cross in-between the islands, was valid. Traffic observations indicated that speeding did not disappear completely. The topography of the location allowed such violations of the traffic rules, the section being straight and therefore providing excellent sight distances on the opposing traffic flow. A few cases of drivers overtaking slow vehicles, in front by passing the island on the right-hand side against the opposing traffic, were reported.
- D. The initial design narrowed the carriageway past the island to 3.0 meters. Most drivers as well as traffic engineers considered this too narrow. Having the entire carriageway deflection past the island, at a constant width of 3.0 meters, was seen as too restrictive. To a degree, this perception reflects the road width which drivers are used to. Maneuvering simulations showed that even the largest truck/trailer combinations could pass on the 3.0 meter lane without much difficulty, if they reduced their speed to around 30 km/hr.
- E. Soon after construction, the curbstones aligning the carriageway at the road shoulder, were damaged by large trucks. This was the result of the unwillingness of the drivers to slow down. The strength of the initially constructed curbstone was insufficient to survive the hits by heavy trucks. Constructing the carriageway/shoulder separation past the islands with T-blocks would have been better. Such a separation is less vulnerable to damage. Furthermore, it commands more respect from the drivers (fear of damage to tires) and therefore assures lower speed.
- F. At the time of repairing the damage to the curbstones, the carriageway was widened to 3.2-3.5 meters in the deflection and 3.0 meters was only maintained at the crossing points. Afterwards, the vehicle tire traces in the sand, accumulated on the carriageway, indicated that a 3.0 meter wide carriageway is, in fact, adequate for all vehicles.
- G. After widening the carriageway, the speeds went up almost to the level of the speeds before the intervention. Table 8.3 below shows the observed speeds before and after the interventions, in three cases. The speed measurement spot was within the section of the islands, at the same spot as before, not at the location of the bump; values in brackets are estimates based on a small sample (N=50), so less accurate.

Table 8-3. Observed vehicle speeds before and after the interventions

	Before the interventions	After the interventions		
		Condition A	Condition B	Condition C
Top speed Km/hr	60	45	60	49
Average speed Km/hr	52*	34*	42	34

A = Initial carriageway deflection design (3.0 m wide), B = Carriageway widened to 3.2-3.5 m
 C = Situation B plus one additional speed bump and * estimates based on a sample of 50 vehicles.

- H. In response to the concerns by the LUP regarding the insufficient safety after the widening, the PPU decided to construct an additional speed bump within the section with the islands. This created a speed reduction to 20 km/hr at the bump, sufficiently low speeds elsewhere and in general, safer traffic conditions.
- I. The use of a continuous line of curb stone, at the road shoulder side to align the carriageway deflections, had some undesirable effects:
 - i. Obstructed water run-off, water flow along the curb line increased and caused erosion resulting in the water flowing sideways;
 - ii. Increased speed of vehicles, compared to single element separators such as T-blocks or bollards; and
 - iii. Increased accumulation of sand and dust on the carriageway along the curb making it particularly inconvenient for the cyclists.
- J. A pedestrian crossing island is a very effective way to create a safe pedestrian crossing point, with minimal pedestrian waiting times and no delays for motor vehicles. However, to create a safe traffic situation, the following design requirements apply:
 - i. Minimum island width 2.0 meters, a minimum carriageway deflection of 1.0 meter. Where space allows, a wider island increases the carriageway deflection and therefore the speed reduction effect. Carriageway with a constant 3.0 meter width in the entire deflection. This forces vehicles to slow down to approximately 40 km/hr (large trucks: 30 km/hr).
 - ii. Where the risk of drivers overtaking the island at the wrong side exists, a total island length of 30 meters is recommended and low median longitudinal bumps (on the road axis) beyond the tips of the island to prevent overtaking on the wrong side of the island.
 - iii. Road shoulder alignment with T-blocks, cannot be ignored by drivers without damaging their vehicle, do not obstruct drainage and do not enhance waste deposits on the pavement. High construction strength of the island, including T-blocks or heavy concrete bollards can assure higher safety for the waiting pedestrians, in case of driver error.

- iv. Reflective arrows on the island indicating the direction of traffic, high bollard painted black/white to show the location of the crossing point, carriageway alignment with T-blocks painted white (or yellow), and island curbstone painted black/white (or red/yellow) provided good visibility. Reflective paint on curbs and T-blocks was not effective, probably due to the high amounts of dust.

8.10 MT-NMT Road Shoulder Separation, Dar es Salaam

Background

Road shoulders for urban roads require designs, which are different from those along rural roads. The need for a strong road base remains the same, but the road shoulder in an urban area must have a defined function. It could be a walkway separated from the carriageway and inaccessible for vehicles, an open drain, an MT parking lane, or a median inaccessible for MVs. Unfortunately, many roads in SSA urban areas have rural road designs, with undefined open road shoulders.



Photo 8.9-1. Pedestrian crossing island, from the pedestrian direction



Photo 8.9-2. Pedestrian crossing island, on a collector road



Photo 8.9-3. Large bus passing a median island



Photo 8.9-4. Overview of three crossing islands

Conditions Prior to Interventions

Some of the conditions prior to the interventions:

- A. It was an urban collector road, with a 7 meter wide carriageway, 1 meter compacted gravel shoulder covered with sand and with a 2-3 meter wide shoulder of naturally compacted sandy soil. The unpaved area parallel to the road was up to 5 meter wide at some spots and which was fully occupied by street traders,
- B. Vehicles frequently drove on/off the road shoulders. This made walking unsafe and unpleasant. A large part of this use of the shoulders consisted of random stopping by minibuses to pick up or drop off passengers.

Problems

Some of the problems encountered were:

- A. The road shoulders were undefined and used for many functions, creating inefficient and unsafe conditions for pedestrians and cyclists. These conflicting uses cause friction and reduce road capacity.
- B. The shoulders were used for:
 - i. pedestrian movement (often, no other walking space was available),
 - ii. street trading,
 - iii. vehicle parking (regular and vehicles waiting for customers),
 - iv. vehicles loading and unloading (goods and passengers), and
 - v. emergency parking and emergency traffic movement
- C. Open urban road shoulders were also the main source of damage to pavements and drains. Initially, potholes formed on the open shoulders. These accumulated water, the road base became soft and the pavement cracks at the edge and around the potholes started to eat into it from the sides, and worsened by vehicles driving on and off the shoulder. The deterioration of the road shoulder had a catalytic effect, further deteriorating the drainage system.

Objectives of Interventions

- 1. The objectives were to:
 - A. Separate the carriageway pavement physically from the shoulder, in such a way that the separation:
 - i. is impassable by motor vehicles (unless at spots where vehicle access is intended);
 - ii. requires minimal maintenance (strong and difficult to damage); and

- iii. creates no drainage problems, solid waste accumulation problems or encourage unintended use of the separators.
- B. Reshape the road shoulder space into a walkway, which could also be used by carts.

Interventions

This intervention consisted of separating the carriageway from the road shoulders by lining it with T-blocks along a 500 meters long collector road section with open road shoulders previously. Different inter-spacing between the T-blocks was used on various parts, to test whether the gap width would significantly influence the effectiveness of the separation from a pedestrian safety point of view.

Cost of Interventions

Costs of applying T-blocks as a separator depended on the gaps between the blocks. With two blocks per 3 meters, total blockage of vehicles was achieved. With one block per 3 meters, the vehicles could still get access at a very low speed. The investment cost for two blocks per 3 meters was around US\$10/m length of road shoulder. Annual costs (costs of capital plus maintenance) were US\$1.60/meter length.

Impact of Interventions

The observed impacts of the interventions were:

- A. Motor vehicle movement onto the shoulders is no longer possible. The pedestrian movement on the shoulders has become much more efficient and relaxed.
- B. On the test section, the number of minibuses, which stop at spots other than in bus bays, has been reduced to almost zero. This depends of course on the simultaneous construction of good bus bays at each end of the road shoulder separation test section.
- C. Traffic movement in and out of plot entrances along the section does not create significant disturbances.
- D. The space between the blocks of 3 to 4 meters appears to be enough to provide a safe separation. However, it does not prohibit perpendicular parking, so on sections with a high parking pressure the inter-spacing of the blocks must be 1.20 meter if parking is to be prevented.
- E. The observed damage to T-blocks suggests that the annual maintenance will be around 2 to 3 percent of the investment, and their lifetime around 15 years. However, good production quality control is required to achieve this.

- F. Observed maximum speeds are reduced slightly, probably because visually the road appears narrower. More tests, with road shoulder separation with T-blocks, are needed in different situations before detailed conclusions can be drawn
- G. The test section was too short to allow reliable estimates of benefits. The test only demonstrates the practical performance of the separator. Based on T-block costs, cost benefit calculations were made to determine what the improvement has to be for each category of benefit to break-even with the costs. Benefits from reduced traffic accidents were not been included in this analysis.
- H. The walkway was a more efficient use of the road shoulder space. Assuming an average increase in walking speed due to the absence of disturbance by vehicles of two minutes per kilometer of road (15 percent faster), the benefit per daily person km was US\$1.00 per year, corresponding to a break-even pedestrian ADT of 1,600 on each side of the road. The actual pedestrian ADT along the test section was around 4,000.
- I. This test road had open shoulders and was reconstructed in 1994/95. Four years later, there was serious pavement damage at all locations with frequent vehicle movement over the road shoulder. Within the next two years many spots, if unattended, will be in such a bad condition that, after only six years, simple re-surfacing will no longer be adequate and complete road base rehabilitation and new pavement will be required.



Photo 8.10-1. A crowd of school children walking, no walkways.

- J. The improvements resulted in reduced cost of pavement maintenance. The current cost in Tanzania of resurfacing an existing carriageway with 5 cm new premix, including pothole repair, is \pm US\$40 per meter of a 3.0 meter wide lane (annual cost of capital: US\$7). The break-even increase in pavement lifetime that justifies the T-blocks as separator is approximately two years. It appears that irrespective of any other benefit, the maintenance aspect alone fully justifies the costs of T-blocks as separator on this type of road.
- K. There is increased capacity of the carriageway. The average new construction costs for a 3.0 meter wide urban road lane, without side restraints, drains, culverts, intersections, and NMT facilities in Tanzania are roughly US\$60 per me-

ter (annual cost of capital: US\$12 per meter lane). This means that an increase in effective road capacity of 13 percent, due to reduced traffic flow obstruction from friction at the shoulder would make the investment in the T-blocks break even. More tests are required to find out what road capacity increase can be created by disciplined minibus stopping in dedicated bus bays.

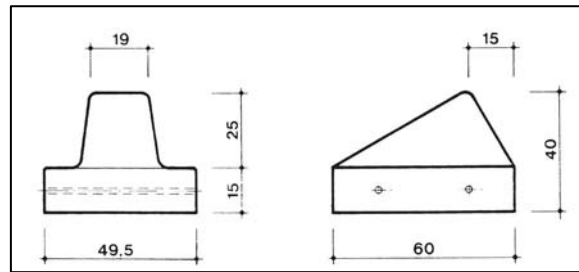

Figure 8-8. T-block production design and T-block 'as made'(left)

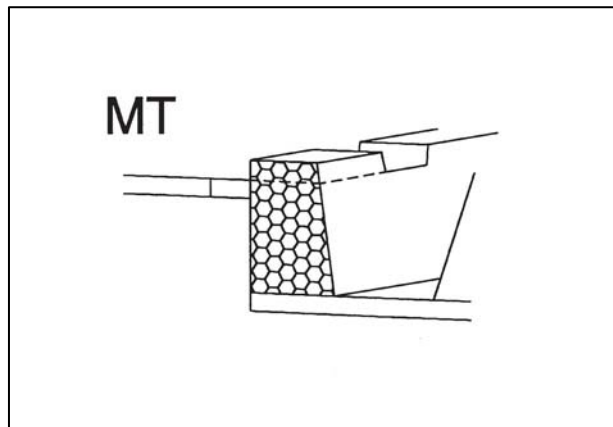

Figure 8-9. Carriageway/shoulder separation with an open drain



Photo 8.10-2. Motor vehicle parking on the shoulders



Photo 8.10-3. vehicle parking on the shoulders, obstructing traffic flow



Photo 8.10-4. Effective carriageway and shoulder separation with T-blocks



Photo 8.10-5. Carriageway and shoulder separation with bollards

8.11 Intersection corner re-design, Temeke and Eldoret

Background

In SSA, many urban intersection corners invite high speed. Often, the shoulder area is not separated from the carriageway, which results in a large undefined area at the corner. In localities with low economic activity, this space generally remains empty, further encouraging high MV speeds. In localities with a higher level of economic activity, the space is in demand by minibuses, taxis, pushcarts and more importantly, the street traders. In general, these conditions lead to chaotic intersections with a reduced capacity. Realignment of the intersection corners to appropriate dimensions, with separators between the shoulder and the carriageway, is a low-cost method of solving the above challenges.

Conditions Prior to Interventions

The conditions prior to the interventions were:

- A. All intersection corners, along Temeke Road were wide and open. It was difficult to decipher where the carriageway ended because of the sand on the pavement. In addition, minibuses frequently used these corners, to load and unload passengers.
- B. Kisumu Road in Eldoret is a main corridor leading into the city center. The intersection corner, chosen for realignment, is immediately after a bridge. The side road, branching off at 45 degrees, is a one-way traffic street (towards the city center).
- C. The pavement condition was fair on the straight legs and poor on the Y-leg.
- D. The average speed of traffic was high at 47 km/hr. The highest observed speed was 82 km/hr. The count for bicycles was 1,800 ADT on the straight legs.
- E. The driver's behavior showed little concern for the safety of pedestrians and cyclists. The expectation that after repaving the Y-leg the already dangerous junction would become even more dangerous was justified.

Problems

The problems encountered were:

- A. Open intersection corners lead to lack of protected pedestrian waiting areas and illegal use of the corner area by parked vehicles, thus causing a chaotic traffic situation and reduced road capacity.
- B. Wide 45 degrees corners lead to the high speed of left turning traffic, long pedestrian crossing distances with unsafe crossing conditions, and a high accident risk for cyclists at the intersection.
- C. Y-junctions between equal roads, with a high proportion of turns leading to a high speed of turning traffic (occasionally minibus drivers even increase speed to slip through a gap in the opposing stream), and a large number of traffic conflicts (20 per day classified "serious", using the Swedish traffic conflict counting method).

Objectives of Interventions

The objectives were:

- A. To create shorter crossing distances and safer traffic conditions by realigning the carriageway corners to a design speed of 10 km/hr for a truck with trailer, allowing smaller vehicles to make the turn at a higher speed,

- B. To separate the shoulder from the carriageway to provide a safe pedestrian area as well as to prevent pavement damage,
- C. To discourage motor vehicle stops at the corner for (un)loading or waiting, and
- D. To reduce the speed turning motor vehicle to <30 km/hr.

Interventions

Three different types of intersection corner re-design were implemented as follows:

- A. Three different designs applied to these interventions are shown in Figure 8.10.
- B. The corners were re-aligned with hard separation between the carriageway and the shoulder, with a smaller radius than before but without the carriageway reconstruction. The “shoulder” area, behind the T-blocks and bollards, was enlarged a bit and the carriageway area reduced correspondingly.
- C. A traffic island, with a slip-lane for bicycles, was constructed to make a wide Y-junction narrower. This intervention was combined with the reconstruction of the approaches to a bridge with a median.
- D. A wide Y-junction was re-constructed to a T-junction. This involved a complete new alignment of the last 100 meters of the Y leg, to make it meet the other road at 90 degrees (T-junction).

Figure 8-10. Intersection corner re-alignment

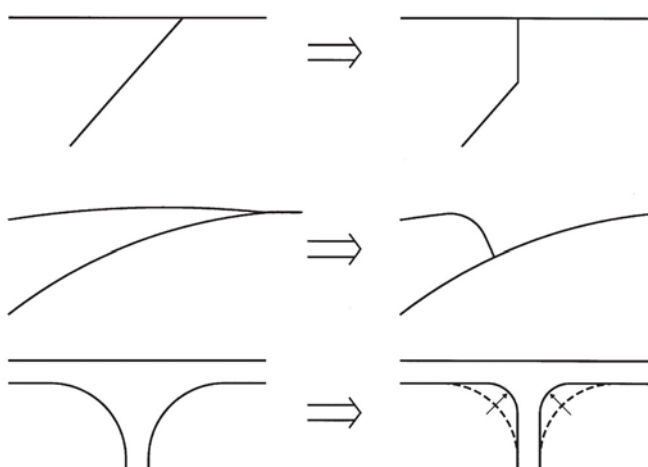

Cost of Interventions

The costs were different in each case of re-alignment, as follows:

- A. Case 1: T-blocks and bollards were used at different spots to realign the corners. The cost of the T-blocks was around US\$10/m of road at the corner. The cost of concrete bollards was approximately the same but damage to the bollards, caused by the vehicles, turned out to be much higher.
- B. Case 2: A traffic island (curbstone) was used to realign the corner and to separate left turning motor vehicles and bicycles. The total costs (part of a much larger package) were around US\$10/ m of curb.
- C. Case 3: Capital costs were US\$4,000 and the annual cost including maintenance was US\$850.

Impact of Interventions

The impacts of the interventions were:

- A. The new corner alignments of Case 1 were fully respected by the road users and had the intended effects: a pedestrianized area at the corner, reduced speeds, discouraging MV stops at the corner and reduced crossing distances.
- B. For Case 2, traffic observations suggested that traffic safety at the spot was restored, to a degree. This also depended on other redesign elements (integrated package of improvements) on this road section, which reduced average MV speeds on Kisumu Road from 47 km/hr to 21 km/hr. The maximum observed speed was reduced from 82 km/hr to 35 km/hr. Due to the increased safety of the route, in which this intersection corner was only one element, the number of cyclists using it has increased significantly (see Chapters 8.6 and 8.12).
- C. The following were the impacts for Case 3:
 - i. Traffic conflicts were reduced to three per day (15 percent of the initial number), thus reducing the risk of accidents.
 - ii. There was no change in traffic flow efficiency, with only slight queuing during the peak hours for the right turns, similar to the condition prior to the interventions.
 - iii. Case 3 was implemented at the time when the road was given a new bitumen pavement. If it had been carried out separately, the cost would have been more than double the US\$4,000 incurred cost (including a pedestrian crossing island), as part of the repaving.
 - iv. This illustrates that by including (re)designs and pedestrian facilities in periodic road maintenance and rehabilitation schemes their costs could be reduced significantly, in particular when the use of asphalt concrete is involved and/or the use of heavy equipment for compaction. There-

fore, integration of periodic maintenance with implementation of traffic calming and NMT interventions is recommended.



Photo 8.11-1. Case 3, after re-alignment



Photo 8.11-2. Case 2, after the construction of the island



Photo 8.11-3. Shoulder of the side road separated from the carriageway



Photo 8.11-4. T-blocks separating the carriageway from the shoulder

8.12 Medians on Kisumu Road, Eldoret

Background

The Eldoret Transport Users Committee identified the Sosiani Bridge and its approaches as very unsafe points and as such a priority intervention. The package of interventions on Kisumu Road included the medians in combination with raised zebra crossings. This section of Kisumu Road enters Eldoret over the Sosiani Bridge and is an important pedestrian and bicycle route into the CBD. The purpose of the medians, at both the approaches to the bridge, was to reduce speeds, making it impossible to overtake other vehicles.

Conditions Prior to Interventions

The conditions prior to the interventions were:

- A. The carriageway was wide, 10 meters at the approaches and 9 meters at the bridge.

- B. The bitumen pavement was in fair condition.
- C. Speeds were very high. The average speed of inbound vehicles was 48 km/hr and the maximum observed speed 82 km/hr, with outbound average speed of 51 km/hr and the maximum observed speed of 72 km/hr.
- D. The above speeds, combined with driver attitudes towards other road users, made it quite unsafe for pedestrians and cyclists.

Problems

The problems encountered were:

- A. Speeds were too high to be safe.
- B. Overtaking of slow vehicles by many motor vehicles, at both the approaches of bridge, endangered the safety of cyclists and pedestrians.
- C. In the absence of walkways, pedestrians used the edge of the carriageway.

Objectives of Interventions

The objectives were to:

- A. Restore disciplined and safe traffic flows.
- B. Eliminate the "black spot" for pedestrians and cyclists.
- C. Facilitate safe pedestrian crossings on both sides of the bridge, without imposing any crossing points.

Interventions

The intervention consisted of two sections of 1.0 meter wide medians (on either side of the Sosiani Bridge). The road corridor was 2x1 lanes. The road sections on either side were 290 meter long. These medians were part of the package of improvements consisting of medians, pedestrian and cycle tracks, drains and raised zebra crossings. Figure 8.11 below shows the details.

Cost of Interventions

Cost of the medians was approximately US\$25/m length. The cost of complete reshaping of the bridge sections (including medians, pedestrian and bicycle tracks, drains and raised crossings) was a total of US\$21,000.

Figure 8-11. Medians on Kisumu Road, Eldoret

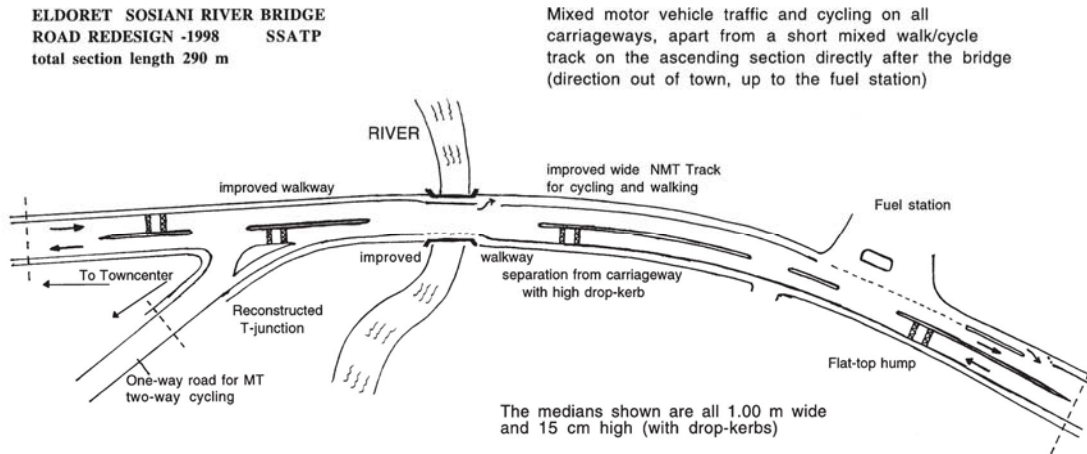

Impact of Interventions

The impact of the interventions were:

- A. A noticeable reduction in speeds. Inbound average speeds went down from 48 km/hr to 21 km/hr and the maximum observed speed from 82 to 35 km/hr. A similar situation happened with the outbound speeds.
- B. Prior to the interventions, this location was the most dangerous section of Kisumu Road and, it was probably its safest section after the interventions. Traffic safety estimates suggest that an average of one fatal accident, three serious injuries and 6 vehicle/vehicle collisions per year would be prevented. This corresponds to a benefit of US\$5,500 (3,000 for fatality, 250/serious injury and 300/vev-veh collisions).
- C. There was a 13 percent increase in cyclists, during the first three months after the opening (180 cyclists per day, inbound; same weather conditions). This increase represents a shift from minibus to bicycles. It was not diverted traffic.
- D. A sudden change of this size is possible because the bicycle ownership was high in Eldoret. After one year, most of the increase in cycling over the bridge had disappeared again, probably because the rest of the cycle route along Kisumu road was still too dangerous (see Chapter 8.5).
- E. The estimated annual cost savings associated with the above initial modal shift was around US\$10,000 (250 days, 180 cyclists at US\$0.23/day). This implies a B/C ratio of 2.3 for modal shift from minibus to cycling. This example shows

that restoring traffic safety would encourage cycling and it is a highly beneficial intervention.



Photo 8.12-1. Kisumu road section, prior to the intervention



Photo 8.12-2. Median on the existing carriageway



Photo 8.12-3. Median on Kisumu road, section leading out of the central business district



Photo 8.12-4. Median on Uganda road, s central business district of Eldoret

8.13 Bus Bays with Raised Zebra Crossings, Temeke Road

Background

In Dar es Salaam, public transport means mainly in minibuses. The minibuses operate in a completely undisciplined pattern. They stop for passengers (on and off) almost anywhere and in a highly unpredictable way for other road users. The negative impact of this on the traffic efficiency is considerable. In addition, the frequent movement of the minibuses to/from the shoulder has a very negative impact on the safety of cyclists and on the pedestrians walking on road shoulders.

Even from a minibus operator point of view, the frequent stopping is costly because it increases the vehicle operating costs and the turn-round time. Operators were aware of this. During peak

hours, once full, they went straight to their destination without many intermediate stops. Off-peak, individual drivers compete to get more passengers. Traffic flow efficiency and bus operating costs would all improve, with a more disciplined operation of minibuses.

Conditions Prior to Interventions

The conditions prior to the interventions were:

- A. Passengers saw little benefit in going to a bus stop to wait there because the bus bays were not necessarily any safer or more attractive spots at which to wait, than any other spot.
- B. Bus drivers look for passengers everywhere because the shape of the road allowed them to stop at any point. This resulted in reducing the drivers' attention to careful driving.
- C. Table 8.4 below shows the modal split for the traffic along Temeke Road at Temeke Hospital. Minibuses were the most important mode, carrying 60% of person trips.
- D. However, the data excludes the pedestrians crossing Temeke Road after alighting from the minibuses. An estimated 8,000 pedestrians crossed the road near Temeke Hospital daily. The maximum hourly crossing observed during 7.00-8.00 AM, in both directions, was 730 pedestrians.

Table 8-4. Modal Split on Temeke Road at the Temeke Hospital*

MODE	walk	cycle	cart	mini-bus	car	LVG	MGV	HGV	m.cyc	Total per day
units	33	12	1	19	13	13	2	3	3	100% (=14,900)
persons	13	5	0	60	10	7	1	1	1	100% (= 39,00)

* Traffic Counts, May 1996

Problems

There were quite frequent and unpredictable stopping maneuvers by the minibuses to pick up or let off passengers. This created an inefficient traffic flow and unsafe traffic conditions for pedestrians, cyclists and motor vehicles.

Objectives of Interventions

The primary objective of the interventions was to find a strategy for making bus bays quite attractive to both the bus drivers and passengers so that a large majority of passengers would get on and off buses at the bus bays.

Interventions

The interventions consisted of building two pairs of long bus bays, which could accommodate 3 to 4 minibuses at the same time. Each comprised 3.0 meter wide brick pavement, raised and paved pedestrian waiting areas (concrete slabs), separated from the bay by high curbs.

The interventions included the following measures:

- A. Provision of large bus bays (capacity large enough for peak bus traffic),
- B. Provision of improved pedestrian waiting areas (with shade trees where possible), dry pavement and no motor vehicle parking,
- C. Construction of raised zebra crossings at the bus bay locations, to force the buses to slow down at the bus bays, to provide safe crossing for passengers before/after their bus trip, and
- D. Separation of carriageway from the shoulders, to discourage random stopping.

Cost of Interventions

Bus bays, described above, were relatively expensive, ± US\$20,000 for the two bus bays. Annual cost, including maintenance, was US\$4,300.

Impact of Interventions

Table 8.5 shows the bus bay utilization by the minibuses after the interventions. Provision of bus bays without accompanying measures, would probably result in only about 30 percent of buses using the bus bays. Provision of bus bays combined with raised zebra crossings and paving of the pedestrian waiting area leads to around 70 percent utilization.

Table 8-5. Bus bay utilization by the minibuses

Direction of Traffic	Percentage of minibuses stopping in the bus bays			
	Bus Bays with RZC		Bus Bays without RZC	
	P.M. Peak	Off-Peak	P.M. Peak	Off-Peak
Trips from the CBD	75	70	75	56
Trips to the CBD	63	75	22	22

Road shoulder/carriageway separation, in addition to the bays, further increases the bus bay utilization by the minibuses.

Most minibus drivers used the bus bays combined with a raised zebra crossing. The use of the bays created a substantially more quiet traffic flow. At the location of three other raised zebra

crossings, most minibuses stopped on the raised zebra crossings to let passengers on/off, since they were forced to slow down anyway.

The general impacts were:

- A. High utilization of the bays.
- B. The number of minibuses, which stopped outside bus bays, was lower where there was a raised zebra crossing, which forced the minibus to slow down and increased bus bay utilization.
- C. On road sections with high passenger volumes, minibuses still stopped more randomly, even where the bus bays had a raised zebra crossing.
- D. Table 8.6 below shows the bus bay occupancy. Even during the peak hours, there was capacity available for more minibuses.

Table 8-6. Bus bay occupancy*

Direction of Traffic	Bus bay occupancy as % of capacity			
	Bus Bays with RZC		Bus Bays without RZC	
	P.M. Peak	Off-Peak	P.M. Peak	Off-Peak
Trips from the CBD	81	65	74	47
Trips to the CBD	72	61	21	21

* 180 buses per hour is defined as 100% occupancy (3 buses max at each bay, one minute/bus)

It was not possible to eliminate random stopping completely with the use of bus bay and raised zebra combinations. Additional measures are required. One is to make the area near the bus bay significantly more attractive for passengers to wait for a bus than other spots. Another is to prevent minibuses stop on road shoulders between bus bays, by physically separating the shoulder from the carriageway. Finally, once set in motion, passengers would increasingly expect them to stop there reinforcing the process of minibuses only stopping in bus bays.

Passenger behavior depends on the supply/demand balance. In general, when the supply of public transport is short (passengers in search of buses), the passengers are forced to walk to a stop where their chance of finding a bus that they can board is greatest. When demand is short (buses in search of passengers) passengers can wait for a bus anywhere along a route (unfortunately without realizing that they have to pay for the system inefficiency that they create in that manner).

However, compared to bus ticket fare, the cost of bus bays is low and benefits from improved operating efficiency of the buses is much higher. The following example illustrates this: on the “Temeke-Posta” bus route in Dar es Salaam (total round-trip distance 17 kilometers), a total of ± 20 bus bay pairs would be required. Some other bus routes would also use these bays, but then they would also be correspondingly larger. The annual cost of these bus bays for the entire route would be ± US\$85,000. The total number of passengers per year on this route was

about 8 million, paying a total fare of US\$1.80 million. Therefore, the cost of requisite bus bays with the raised zebra crossings along the entire route would amount to about 5 percent of the current fare revenue. No detailed analysis of vehicle operating costs of the buses is available. A rough estimate of fuel and maintenance costs suggests that more efficient minibus operations brought about by a systematic use of bus bays, would create fuel and maintenance savings in excess of 5 percent of the fare revenue (not counting turn-round time reduction).



Photo 8.13.1. Minibus stopping at road shoulder, prior to the intervention



Photo 8.13.2. Same location as above, after the construction of the bus bay



Photo 8.13.3. Buses stopping on the shoulders before the interventions



Photo 8.13.4. Same location, after the construction of the bus bays

8.14 Road Narrowing with Bicycle Slips, Morogoro

Background

Cycling is the second most important travel mode (walking being the first), in Morogoro. It accounted for about 20 percent of all daily trips in 1996 (household survey) and appeared to have slightly increased by 1998 (mini-survey). In 1998, the pavement condition of the roads in Morogoro was in such a bad state that high speeds rarely occurred, thus rendering a safe cy-

cling environment. The only exception was the 15 kilometer length of national trunk road (Tanzam and Dodoma highways), passing through the center of Morogoro, which could be avoided for most bicycle trips within the city. However, the rehabilitation of the main roads in the city (14 kilometers in total), undertaken between the end of 1998 and 2001, changed this situation drastically. To safeguard and strengthen the position of cycling in Morogoro, a bicycle network plan for the entire city was developed.

Conditions Prior to Interventions

The conditions prior to the interventions were:

- A. The ADT for all vehicles, including NMT was \pm 8,000, of which 65 percent were bicycles, 35 percent motor vehicles. The test locations had a large volume of cyclists.
- B. The carriageway was wide, varying between 8 and 10 meters.

Problems

The primary problem was the speed, many vehicles driving at $>$ 50 km/hr, leading to unsafe traffic conditions.

Objectives of Interventions

The objectives were to:

- A. Reduce the speed and increase safety for all road users,
- B. Visually separate traffic lanes (3.0 meter wide) and bicycle lanes (1.5 meter wide),
- C. Increase the use of the designated lanes by both motor vehicles and cyclists.

Interventions

The basic design for the proposed bicycle network consisted of:

- A. Mixed cycling on the main roads in the CBD and on bicycle lanes, visually separated from the motor vehicle lanes;
- B. Mixed cycling on all secondary streets, with motor vehicles and bicycles using the same lane; and
- C. Separated bicycle tracks on the main corridors outside the CBD, where speed would increase to around 50 km/hr.

The mixed traffic design in the CBD would function satisfactorily only if the MV speed remained low enough. Since this was not expected to happen, merely in response to posting the

speed limits (or a safe driver behavior campaign), physical traffic calming measures were found to be necessary. For mixed traffic roads with bicycle lanes, a road narrowing with bicycle slips was one of the options.

Road narrowing with bicycle slips was constructed at two locations, approximately 400 meters apart on the same collector road. The carriageway width was narrowed to 5.0 meters. The separation islands were 0.80 meter wide and the bicycle slip lanes 1.20 meter. The islands were 10 meter long, with a gap in the middle to facilitate crossing by pedestrians. Figure 8.12 shows the adopted bicycle slip design.

Figure 8-12. Bicycle slips in Morogoro

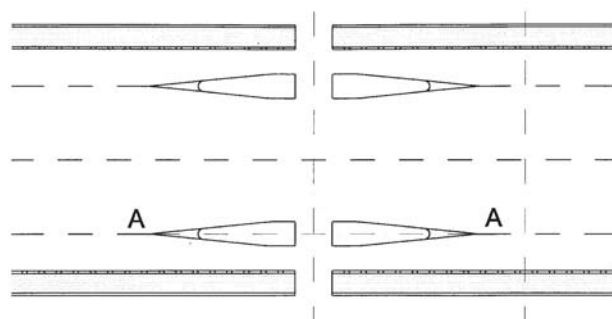

Cost of Interventions

The total cost was about US\$1,500 (excluding the simultaneously constructed pedestrian bridges). To achieve the objectives of the intervention over an entire road section, road narrowing should be carried out at least on four sections per kilometer, depending on the specific conditions. Based on this, the estimated cost would be about US\$6,000 per kilometer of road. Annual costs, including maintenance, would be US\$1,200.

Impact of Interventions

When the motor vehicles were approaching from both sides, cyclists used the bicycle slips. When not forced by the motor vehicles to use the bicycle slips, most cyclists used the middle gate, this because the pavement of the middle section was much better. For proper permanent use of the slips, their pavement quality must be good.

In the middle of the islands, which separate the bicycle slips from the motor vehicles traffic lanes, a low part was provided (level with the carriageway) as a pedestrian crossing. However, to use that crossing point required a detour of 25-50 meters. Most pedestrians did not bother to make this detour, but crossed in front of the road narrowing, using the “shade” of the separation islands as a waiting spot, if needed.

The existence of the narrowing reduced the effective crossing distance and the speed when the vehicles came from both directions. As a result, crossing at this point was safe, even if one did not use the islands as “stepping stones”. Nevertheless, this intervention (effective for traffic channeling), was not ideal as a crossing facility. To improve the users’ awareness that these are attractive pedestrian crossings, the islands should be wider (ideally two meters) and constructed in the centerline of the main pedestrian route (not requiring a small detour).

Increased bicycle traffic safety was the most important benefit. To estimate the value of this benefit, one could calculate the added transport costs, which would arise if an increase in accidents hazards would lead to a modal shift from cycling to minibuses. The additional cost of such a modal shift would be about US\$6,900 per 100 cyclists daily (300 days * 100 cyclists * US\$23 per cyclist per day = US\$6,900).



Photo 8.14-1. Road Narrowing with Bicycle Slips in Morogoro

For example, if road rehabilitation in Morogoro would be carried out without proper traffic calming and therefore as a result, reduce the number of cyclists by 20 percent (shifting to the minibuses), it would mean a travel cost increase of ± US\$50,000 per year for the road users. Bicycle use promotion and traffic safety protection measures are very cost effective.

8.15 Bicycle Track along an Urban Corridor, Eldoret

Background

The main road corridor through Eldoret CBD combines its urban center function. It also serves as a corridor for through traffic to Uganda Road. This road section was repaved in the 1980’s as an undivided, ±16 meter-wide, 2x2 lane road, excluding the parking area. Outside the CBD, it again becomes a wide 2x1 lane road. About 1990, a one meter-wide median, in part of the 2x2 lane road section was constructed, as a response to the high number of accidents. However, with growing traffic volumes, once again the accident rates rose quickly.

Apart from the median, no other traffic calming measures were even considered until the pilot projects. The road has two lanes. One side of the median is sometimes illegally used for parking. On the other side, where there are many shops, it was wider and had two traffic lanes with space for angular parking. Parking was irregular and consisted of all types of vehicles including trucks. Therefore, in practice, only one wide lane was available for the traffic.

Cyclists shared this lane with the motor vehicles. On the side of the shops, space for pedestrian movement was very limited. The shopkeepers had installed verandas by encroaching onto official walkway. Walking at a normal speed was impossible and resulted in many pedestrians walking on the carriageway.

Conditions Prior to Interventions

The conditions prior to the interventions were:

- A. Chaotic traffic conditions was reducing the efficiency and safety of traffic flow;
- B. A significant portion of the through traffic was transit traffic of heavy trucks, which resulted in serious traffic safety hazards;
- C. The condition of the bitumen pavement was fair;
- D. Pedestrian walkway capacity was quite insufficient;
- E. ADT consisted of 17-20,000 pedestrians, 2,500- 5000 cyclists (varied per section) and 8-12,000 motor vehicles (varied per section).
- F. At the main junctions, the NMT crossing volumes during the peak hour, were 3000-3,500 pedestrians and 200-350 cyclists.

Problems

The problems encountered were:

- A. The traffic conditions on Uganda Road (the main road corridor) were very unsafe. On Uganda Road (\pm 5 kilometers), an average of about 30 persons were killed in traffic accidents every year during 1993-1995. This is equivalent to six fatalities per year per kilometer of road! Most of the fatalities were pedestrians and cyclists, and the number of accidents was increasing.
- B. The use of the existing carriageway was inefficient.
- C. Walking speeds were very low, an estimated 2.5-3.5 km/hr, on the side of the shops.

Objectives of Improvements

The objectives were to:

- A. Create safer and more efficient traffic conditions for cyclists,
- B. Improve the attractiveness of cycling and reinforce user confidence, so that in the long term, cycling would be safeguarded as a viable travel mode, by the municipal authorities of Eldoret, and

- C. Increase the efficiency and capacity of the motorized traffic flow and to effectively demonstrate that “win-win” solutions are possible.

Interventions

This intervention was an attempt to reallocate the road space on the side of the shops by:

- i. Enforcing the shopkeepers to keep clear of the walkway (the verandas had been built on the public road reserve),
- ii. Constructing a bicycle track, separated from the carriageway by the parallel-parked vehicles, thus changing the parking pattern from angular to parallel.

This intervention consisted of the construction of a 500 meters long bicycle track along an existing road by rearranging the parking and traffic lanes. The cycle track is on the existing paved road shoulder, separated from the parking lane by high curbs. Figure 8.15-1 below shows the road system and the proposed bicycle tracks.

This also re-established two 3.0 meter lanes.

The bicycle track would function effectively if it was used exclusively by the cyclists. Therefore the enforcement of an unobstructed walkway in front of the shops was essential.

Cost of Interventions

The total cost of the new track was US\$18,000 (US\$30/meter). The annual cost (including maintenance cost) was US\$3,900. This cost was for a 600 meter long section and includes all separators and pavement repairs. It did not include any new pavement costs.

Impact of Interventions

Eldoret municipality was unable to enforce the shopkeepers to leave the verandas in front of their shops free for use as a pedestrian walkway. In retrospect, it was "wishful thinking" that this would be possible. Consequently, the pedestrians used the new “bicycle track” and almost all cyclists continued to use the carriageway.

Fortunately, it is a tremendous amenity for the pedestrians. Walking speed and safety had improved considerably for them because they no longer walked on the carriageway.

The new track remained free of parked vehicles. The separation with high curbs effectively blocked vehicle access to the track. However, effective enforcement will be needed to prevent shop owners from removing these blocks to increase the parking space in front of their shops.

After the improvements, parking was parallel to the traffic flow. This created a smoother and safer traffic flow, and had a positive effect for cyclists on the carriageway. However, the obligation, to park in parallel, must be enforced. Occasionally, some drivers still parked angularly.

The benefit from increased walking speed was \pm US\$1.20 per pedestrian per year, or US\$6,000/year, assuming that half the pedestrians walked longer distances daily. The track has a B/C ratio of 1.5 as a walkway, without taking into account the benefits from traffic accident reduction.



Photo 8.15-1. Traffic conditions, prior to interventions



Photo 8.15-3. Traffic conditions, prior to interventions



Photo 8.15-2. Same location as above, after the interventions



Photo 8.15-4. Same location as above, after the interventions

It would be necessary to take effective measures to achieve safe cycling conditions. The associated benefits are two fold: avoided costs of accidents involving cyclists and further modal shift from bicycle to minibus. These benefits are significant. If only one fatal bicycle accident and four serious cyclist injuries can be prevented per year (25 percent reduction in the accident rate), the avoided cost of accidents is US\$4,000.

Yet, the trend was towards reduction in cycling as a response to increasing traffic accident hazards. If a 5 percent reduction of cycling along Uganda Road could be prevented by improved

safety, the associated cost saving would be US\$14,000 (300 days*200 cyclists* US¢0.23/day). This underlines the benefits of safeguarding cycling as a transport mode in Eldoret.

8.16 Mixed NMT Track on Uganda Road (Urban Corridor), Eldoret

Background

This intervention section was on Uganda Road where it enters the city of Eldoret and passes through an area of light industries and workshops. The vehicle speed on this section was high and created many accidents. The Mitaa Junction (Y-junction), at the entrance to the city, was particularly dangerous.

Cycling is an important transport mode in Eldoret. With the road conditions and intersection designs, which existed at the time of the interventions, traffic safety decreased with increasing motor vehicle traffic.

Pedestrians could only walk on unprotected open road shoulders. The vehicles speed and volume made it difficult for mixed use of the same carriageway in a safe manner.

However, it would be possible to increase the traffic safety for cyclists even with much higher volumes. Such a strategy would require that:

- A. Cycling would have adequate road space. Even where there was limited road capacity to satisfy the competing demands of motor vehicles and NMT, there was a need to provide safe road capacity for cyclists; and
- B. Traffic calming measures were introduced to reduce speeds to safe levels and the traffic law would be enforced to enhance disciplined and safe traffic behavior.

Conditions Prior to Interventions

The conditions prior to the interventions were:

- A. Observed maximum speed, on the approach road at the entrance to the city, was 70-90 Km/hr and was 62 km/hr at Mitaa junction. Reduction of maximum speed to 50km/hr, was considered desirable.
- B. A large numbers of heavy trucks (fuel tankers, trailers with containers or logs) used Uganda Road on long distance trips.
- C. The pavement was in fair condition.
- D. At the intersection with Mitaa junction, the ADT (12 hour count) was: 10,200 motor vehicles, 4,200 bicycles and 15,800 pedestrians.

Problems

Problems encountered were:

- A. There were many accidents involving pedestrians and cyclists.
- B. There were no designated walkways or safe crossings. Pedestrians used the open shoulders.
- C. Cyclists shared the MV carriageway.
- D. At the time of the interventions, the MV carriageway was not yet at maximum capacity during the peak hour. However, in the long term, the existing carriageway would not be able to accommodate the expected increases of MV and bicycle traffic.

Objectives of Interventions

The objectives were to:

- A. Reduce traffic accidents significantly;
- B. Provide adequate road capacity for both MVs and cycling; and
- C. Improve the attractiveness and safety of cycling and reinforce user confidence in cycling.

Figure 8-13. Road network in Eldoret CBD, with the bicycle track

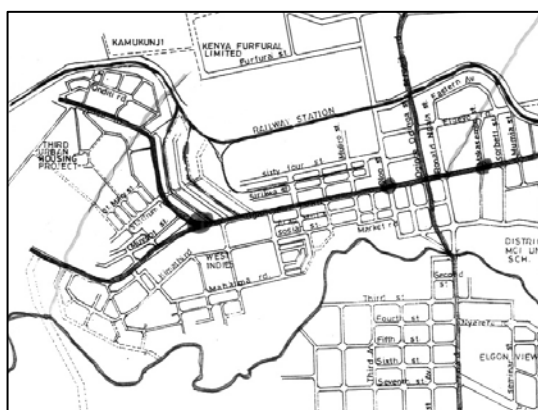

Interventions

This package of interventions consisted of constructing a 400 meter long separate mixed-NMT track (2.5 meter wide, premix pavement), two pairs of two speed bumps (1:10, 10 centimeter high), repairs to drainage culverts, construction of one crossing island where the track crossed a side street, road signs and painting. Figure 8.13 shows the road network and the NMT tracks.

Figure 8-14. Design of the proposed 500 meter length NMT track

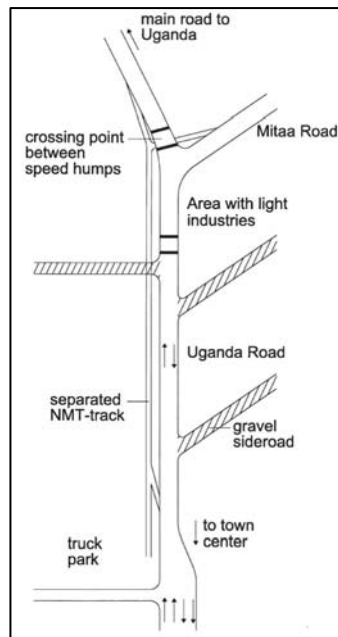

Cost of Interventions

Total cost of the interventions was US\$25,000. This corresponds to an annual cost of US\$5,300 including maintenance costs. The NMT track cost was about US\$11.00/m² and US\$27.00/m track length.

Impact of Interventions

Except those with a destination on the other side of the road, most pedestrians used the track in both directions. After the completion of the mid-block crossing, protected by the speed bumps, the use of the track by pedestrians increased further.

Most cyclists (70-80 percent) continued to use the carriageway. A week of active publicity and instruction to cyclists at the site, urging them to use the track, did not change much for a number of reasons:

- A. The speed bumps were very effective in reducing speed at the important crossing points (Mitaa junction and mid-block). In addition, they considerably reduced speeds between the bumps. Cycling on the carriageway became much safer.
- B. Pedestrians were essentially an obstruction on the track for the cyclists.

- C. The track required a small detour and covered only 400 meters of a much longer trip, the rest being of mixed traffic.

The fact that most cyclists continued to use the carriageway, was in itself not a negative result. With the new track, pedestrians no longer walked on the road shoulder and therefore, traffic flow was more efficient. Furthermore, the speed bumps had slowed down the traffic so effectively that mixed cycling was now safe enough on this section. The new track was primarily a very useful and highly needed walkway. At the same time, it provided a cycle track for those cyclists who felt insecure on the main carriageway.



Photo 8.16-1. The new NMT track

The problem of conflicting pedestrian/cyclist traffic characteristics and competition for the track was stronger than anticipated. The width (2.5 meters) turned out to be too narrow for a two-way traffic of both pedestrians and cyclists. At a peak, one direction pedestrian flow of 2,000 persons, a minimum width of 1.0 meter is required and for up to 1,500 cyclists, another 1.0 meter-wide lane is required. Combining the two on one track requires an additional “friction” width of 1.0 meter. As long as the entire flow was in one direction, this new track (2.5 meters) could just accommodate the flows

(with small delays). However, for two-way flows, the track was too narrow. For the peak flows (2,000 pedestrians and 1,000 cyclists), either one-way mixed pedestrian/bicycle tracks of 3.0 meters on both sides of the road or separate two-way tracks, 2.5 meters for pedestrians and 2.5 meters for bicycles, were desirable.

Since the completion of the intervention with speed bumps in December 1997 to June 1999, no fatal accidents occurred on this section of Uganda Road (almost one and a half year), compared to an estimated 4-6 fatalities per year prior the interventions.

It was possible to achieve the objective of assuring enough road capacity for both cyclists and motor vehicles. The carriageway was wide enough, 9 meters, in which the bicycles had their own space. The traffic had been calmed down and pedestrians were no longer using the carriageway/shoulders, the capacity for both motor vehicles and cyclists was more than enough.

Everybody could now see that it was possible to restore traffic safety for cyclists with relatively simple interventions. It was also possible to achieve the objective of improving the attractiveness of cycling in Eldoret, by eliminating a dangerous spot for cyclists. This spot had earned the reputation of being a major safety hazard, after the publication of many accident photographs in the newspapers.

A mixed NMT track of this type works well for pedestrians but not for cyclists. Too many pedestrians chase the cyclists away. The "lesson learnt" was that the provision of a separate cycle

track will not work where there is a significant flow of pedestrians who have no proper walkways. The pedestrians will certainly occupy the new cycle track! A separate cycle track can function well only if sufficient walkways are available for pedestrians. If no sufficient walkways exist, then proper walkways should be provided.

A mixed track for the combined use of cyclists and pedestrians can only be hoped to function properly if:

- A. It is for traffic in one direction only with a track on each side of the road; and
- B. It is wide enough in view of the pedestrian and bicycle volumes using it.

A two-way cycle track on one side of the road can only function efficiently if cycling is not mixed with pedestrian movement.



Photo 8.16-2. New cycle track, passing a side road



Photo 8.16-3. Entrance to the new cycle track, from the CBD

The benefits of the interventions were as follows:

- A. For every 100 persons who decided to use a bicycle for their daily trips instead of a bus, the annual saving on transport costs was US\$7,000 (see Chapter 8.15). Therefore, a 10 percent increase in cycling on this route would amount to 200 persons shifting to bicycles (400 bicycle trips per day) for their daily transport.
- B. The reduction in the number of fatal accidents, on this section of Uganda Road, was estimated to be five accidents per year. The associated benefit was estimated at US\$15,000 (fatalities only, excluding vehicle damage and injury accidents. The estimated B/C ratio of this intervention is around 3.0, based on accident prevention alone.

8.17 Learning from Errors, Dar es Salaam Road, Morogoro

Background

As part of the pilot projects, a bicycle network plan was prepared together with designs for major routes. Subsequently, the municipality officially adopted this plan. The long-term goal was to design and implement a bicycle route network, with a capacity to accommodate all daily trips, providing safe traffic conditions and offering direct bicycle routes. Proper design recommendations were prepared in detail by the local government professional staff.

During May-September 1999, the municipal government decided that, due to budget constraints, all infrastructure facilities regarding traffic safety and NMT, be removed from the plan of reconstruction of the Old DSM Road. As a result, road rehabilitation became primarily the reconstruction of the existing road into a smooth carriageway for the motor vehicles, without any obstacles to the traffic flow.

As a net result, what was supposed to be a comprehensive package of improvements for all modes (motor vehicles and NMT) emerged to be pavement reconstruction with only a focus on motorized traffic.

Conditions Prior to Interventions

The conditions prior to the interventions were:

- A. The pavement quality in general was very low, except for a small number of sections in fair quality. The vehicle operating costs were much higher than on a good paved road.
- B. This was an urban collector road, with a high volume of pedestrians and cyclists. Bicycles comprised 55 percent of all vehicles on the road and 60 percent of all persons moving on the road were either pedestrians or cyclists. This road is the main NMT route from the eastern part of the city to the CBD.
- C. The ADT in 1996, on the busiest section of the road, was 7,600 pedestrians, 6,200 bicycles, 1,300 cars, 130 minibuses, 3,200 trucks (94 percent of them large trucks) and 500 motorcycles.
- D. There were no serious accessibility problems, not even in the wet season.
- E. The motor vehicles, due to bad pavement conditions, had to limit their speed on most stretches of the road to 40-50 km/hr. However, on the fair pavement stretches, traffic calming interventions had already been implemented (under the pilot projects) reducing the top speed from 60 km/hr to around 50 km/hr.
- F. During 1997 and 1998, no fatal accidents on this road occurred.

Problems

Problems encountered were:

- A. Because of very low pavement quality, vehicle operating costs were quite high and owners complained bitterly to the authorities.
- B. Pedestrians had to walk through the dust blown by the traffic. During the wet season, walking speed reduced considerably due to bad conditions of the pedestrian track.
- C. The bad pavement condition did not affect the cyclists very much.

Objectives of Interventions

The primary objectives of the interventions were to:

- A. Reconstruct a smooth pavement, with a wide carriageway, thus providing for an efficient traffic flow without any obstacles, and to
- B. Test the appropriateness of the cold asphalt concrete pavement for local conditions.

Interventions

This intervention consisted of repaving the old Dar es Salaam Road with asphalt concrete cold mix and removing any obstacles to traffic flow. The reconstruction was completed without the provision of any NMT facilities.

The Dar es Salaam Road is an urban arterial road, which was upgraded to trunk road standards. It was reconstructed to a 7.0 meter wide new carriageway, with 1.5 meter wide-open shoulders (surface dressing) towards an open drain.

Impact of Interventions

The construction was completed in October 1999. Pedestrians, cyclists and motor vehicles shared the same road space in a chaotic manner. Furthermore, the speeds increased further after the interventions. In the first three months after opening, three persons died in fatal accidents. The road had become very dangerous, in particular for cyclists and pedestrians. Proof that this type of urban road rehabilitation brings no improvement, but creates a significant deterioration of the overall mobility situation, could hardly have been given more convincingly.

Pedestrian bridges over the side drains and small streams were not provided. They would have to walk on the road shoulders, at these points. This type of road rehabilitation does not bring any improvements but results in a significant deterioration in the overall mobility of the low-income population. The photos below illustrate the problems and the lessons from experience.



Photo 8.17-1.
Old DSM Road, after widening in 1999. Wide
carriageway, high speeds, lack of dedicated
space for NMT, unsafe traffic conditions



Photo 8.17-2.
Old DSM Road bus bay in 1999



Photo 8.17-3. Entrance to the regional hospital,
after the NMT improvements in 1977



Photo 8.17-4. Same location in front of the
hospital after the road widening and paving
in October 1999. Chaotic and unsafe traffic
conditions, compared to 1997

9 LESSONS FROM EXPERIENCE

9.1 Urban Mobility in SSA (Details in Chapter 2)

In most cities of SSA, urban mobility is very low. It varies from a very low of 1.7 trips per person per day in Morogoro, 1.9 in Dar es Salaam, 2.2 in Kinshasa and Nairobi, 2.7 in Eldoret, 3.1 in Bamako, and 3.2 trips in Dakar. Several SSATP studies indicate that low mobility leads to low urban productivity. Much of this low mobility is a result of urban poverty in SSA.⁷¹

The urban poor are NMT dependent. NMT infrastructure improvements and the associated efficiency increases regarding walking and bicycling, will increase urban productivity. The income status of the urban poor is not likely to change much over the next few years to 2015. Whether the incomes of the poor will increase or not, making improvements to NMT infrastructure will increase urban productivity.

Lesson #1: *Improvements to the NMT modes, predominantly used by the poor, could be useful instruments for increasing the productivity of the poor in particular and urban productivity in general.*

There is an overwhelming dependence on NMT, particularly on walking, by a large portion of the urban population. In most SSA cities, walking trips account for about 50 percent of all trips. At the same time, for those who walk, the conditions are arduous and unsafe as there is a complete lack of physical infrastructure dedicated exclusively for walking and bicycling to assure their efficiency and safety. Urban transport efficiency, including that of NMT, has major impacts on urban productivity and labor market efficiency, which affects all urban residents and not just the poor.

Walking trips vary from 42 percent of all daily trips in Ouagadougou, 60 percent in Bamako, 70 percent in Addis Ababa to 81 percent in Dakar. In smaller cities like Morogoro, 67 percent of all daily trips are by walk. About 90 percent of the walking trips, were <5 kilometers in length in Temeke and Morogoro. If urban transport has to serve the needs of the majority of road users, it is evident that substantially more attention is required for more efficient urban planning and design of urban transport infrastructure, including for all NMT users.

⁷¹ John Howe and Deborah Bryceson, Poverty and Urban Transport in East Africa: Review of Research and Dutch Donor Experience, (Étude Mobilité Urbaine et Transport Non Motorisé des Ménages les Plus Pauvres - PUTEA), 1993-1999, SSATP Report, December 2000.

Lesson #2: *It is very likely that walking will continue to be the dominant urban transport mode during the next decade in SSA, planning and implementation of necessary pedestrian infrastructure facilities must be central to mobility policies and mobility planning.*

Cycling is not popular in the large cities of SSA. Cycling accounted for only 1 percent to 2 percent of all daily trips in Nairobi, Bamako, Harare, Niamey and Dakar. It amounted to 3 percent in Dar es Salaam, and 10 percent in Ouagadougou. However, cycling is more popular in the smaller cities: 12 percent of all daily trips in Eldoret and 23 percent in Morogoro.

Accident rates are very high in the large cities; 14 fatalities/100,000 people (35/10,000 vehicles) in Dar es Salaam and in Nairobi 32/10,000 vehicles. They are extremely high compared to one to two fatalities/10,000 vehicles in the EU. It is also unsafe to cycle in most cities.

Lesson #3: *Cycling is a healthy and efficient mode of transport, which can be within the reach of the low-income households. Unless the overall traffic situation is safer, cycling does not appear to have a significant potential for increase in the large cities. However, the smaller towns offer a major potential to increase cycling as a daily travel mode.*

Road transport is the dominant transport mode in SSA and walking the predominant mode. In 1999, the typical door-to-door travel speeds for different modes in Nairobi were: walking 3-5 km/h, cycling 10-12 km/h, motorcycle or moped 15-20 km/h, buses and minibuses 8-12 km/h and cars 15-17 km/h. This inefficiency has led to very unproductive urban conditions.

Mixed traffic conditions prevail. Pedestrians, cyclists, motor vehicles, animal driven carts (in a few countries only) and hand carts, trucks and other goods vehicles, all share the same road space, more or less indiscriminately. The rule often appears to be, "occupation of the road means ownership of the road".

Lesson #4: *If the primary objective is to provide a safe and efficient travel environment, then a very high priority must be given to traffic law enforcement, staff training, road user education and, traffic management. This has to be a long-term commitment as it requires a quantum leap in urban traffic culture.*

9.2 Urban Mobility in the Pilot Project Cities (Details in Chapter 3)

Urban mobility was very low in the pilot project cities. It was 1.7 in Morogoro, 1.96 in Dar es Salaam, 2.24 in Nairobi and 2.7 in Eldoret. Most of the daily trips were <5 kilometers, 55 percent in Dar es salaam and 74 percent in Morogoro. 47 to 48 percent of all daily trips in Dar es salaam, Nairobi and Eldoret were by walk and 67 percent in Morogoro.

NMT trips (walking and cycling) accounted for 48 percent of all daily trips in Nairobi, 50 percent in Dar es salaam, 60 percent in Eldoret and 90 percent in Morogoro. Smaller cities also have more cycling. Cycling trips were a negligible 1 to 3 percent in Dar es Salaam and Nairobi. However, cycling accounted for 12 percent of all daily trips in Eldoret and 23 percent in Morogoro. NMT trips, as a proportion of all daily trips, increase with decreasing city size (smaller geographic size).

Lesson #5: *Smaller cities offer a substantially higher potential to increase the use of bicycles for daily travel. The backlog in pedestrian infrastructure is largest and most acute in the large cities.*

9.3 Institutional Aspects and Project Management (Details in Chapter 4)

Links to Other Projects

The NMT Program activities were required to develop strong links with the Kenya Urban Transport Infrastructure Program (KUTIP) and the Tanzania Urban Sector Rehabilitation Program (USRP). However, aside from some small infrastructure works, awareness raising and training, the Pilot Project Program (PPP) had a much smaller impact on KUTIP than had been originally thought. KUTIP project designs in Nairobi were well advanced by the time the International Consultants tried to exert influence. The government and the World Bank both *de-facto* resisted co-operation, *on the argument of the risk of delays. In practice, works under KUTIP only started in 1999, after completion of the NMT pilot projects.*

An example of successful linkage was the major road rehabilitation program in Dar es Salaam, funded by the Japanese Government. It included several NMT improvements, primarily because the local professionals had the experience of the pilot projects by then and in addition, the same Japanese contractor had been previously involved in the pilot projects in Temeke. Another example is the Morogoro PPU who, with the assistance of the National Team, persuaded two major World Bank funded programs (Integrated Road Project - IRP and the Urban Sector Road Program - USRP), to include NMT infrastructure within their projects in Morogoro. As a result, by 2003 a substantial number of the roads in Morogoro had NMT infrastructure facilities and traffic calming aspects.

Lesson #7: *Building successful links to other major urban transport projects is important. Successful linkages depend upon timing of the projects, client attitudes and the commitment of the lending agencies and donor agencies to the need and importance of cooperation. At the operational level, it is important that the Task Team Leaders (both the Bank and the Client) of the linked projects are sensitive to and interested in building NMT infrastructure facilities.*

Pilot Project Units (PPUs)

The PPUs were the nerve center of the project because they were responsible for implementation. There was noticeable disparity between the national teams and the PPUs in terms of professional experience, remuneration and attitudes towards NMT. PPU staff was aware of the fact that the pilot projects and the consultants (national and international teams) were *funded* by the international donor agencies and the Bank. PPU's had no final say in project budget allocation details and at times, this caused resentment. Because of the project TOR (the investments being pilot- scale tests), the allocation of project investment funds was decided by the consultants in consultation with the SSATP project manager.

Lesson # 8: *To achieve success, consultants (both international and national) should be transparent from the beginning regarding the available project funds, their allocation and use. There should be no false promises or expectations.*

All the four PPUs were dissolved upon completion of the pilot project and after a short period of monitoring, primarily because there was no follow-up to the project in the form of further up scaling of NMT investment, as originally envisaged in the project set-up. The two areas of weakness of the projects were: (a) a lack of commitment at decision-making level of the local authorities participating in the project; and (b) a lack of effective dissemination of the lessons learned, after the project.

Lesson #9: *Institutional structures should enable proper empowerment of the local authorities as it creates a sense of ownership and perhaps continuity.*

Management Structure

The structure adopted was essentially *top-down*, which was probably necessary to ensure that deadlines were met and the physical outputs achieved. However, the sustainability of the pilot activities depended on the local authorities and the users occupying the center of the implementation framework and being in charge of the development process. This certainly met the deadlines, resulted in an increase in public awareness of NMT issues and allowed for the testing of a wide range of NMT measures. However, it quite possibly undermined the progress towards the other core objectives of the project, namely institutional development and capacity building within the local authorities.⁷²

The local authorities and the users should be closer to the center of the processes for implementing the NMT program and managing the linkages to other projects. One of the important objectives of local authority control over the interventions is to balance potentially conflicting approaches championed by various stakeholders with the actual needs of the residents. A key

⁷² Scott Wilson, Op. cit.

constraint was the effective sidelining of the local authorities through the organizational structure put in place for both the NMT Program and KUTIP.⁷³

Lesson #10: *The management structure adopted for the NMT project implementation should put the users and the local authorities at the center of the process of implementation. This empowerment is a pre-requisite to continuity.*

Capacity Building

Local governments in SSA require systematic training and long-term organizational support to enable them to develop the required “*corporate knowledge and experience*” to deal effectively with the problems faced by the NMT users. The long-term objective of the pilot projects was to facilitate the establishment and reinforcement of the municipal capacity to design and implement affordable urban mobility policies, in particular non-motorized transport policies targeted at the urban poor. Training programs and access to national and international consultants were certainly positive instruments of building local capacity. The second main output of the pilot interventions was a significant increase in awareness amongst politicians, planners, engineers and the public of the importance of addressing the needs of non-motorized transport.

As part of mobility planning undertaken by the PPU, the international team, with the assistance of the national teams, conducted training and continuing education programs for the staff members of all the PPU. This program put them all on “*a very steep learning curve*”. In addition, the international consultants conducted training courses and seminars on NMT for government engineers and planners, local authorities (decision-makers) and private consultants. The training increased awareness at all levels and contributed to the incorporation of NMT measures into the other projects in several centers (other than Nairobi).

Lesson #11: *Training is an important strategic instrument for not only disseminating new knowledge but also for capacity building and for increasing the awareness of the needs of NMT users.*

The primary thrust, to providing for NMT infrastructure, was to put road users at the center of the planning process. However, the pilot project activities were constrained by short time frames and the need to show results. Therefore, NMT Consultants (international and national teams) had to take charge of the process. This certainly met the deadlines, resulted in an increase in public awareness of NMT issues and allowed for the testing of a wide range of NMT measures. However, it quite possibly undermined the progress towards the other core objec-

⁷³ Ibid, p. 47.

tives of the project, namely institutional development and capacity building within the local authorities.⁷⁴

Capacity building in the local authorities was limited to increasing the awareness of NMT issues, the training of some municipal staff and practical experience related to the performance of the spot interventions. The challenge is to bring appropriate NMT infrastructure planning into government policy and to incorporate NMT design aspects into urban road design manuals, with an equivalent importance similar to current standards required for motorized transport.

Lesson #12: *To ensure long-term capacity building and continuity to the commitment of improving NMT infrastructure, local authorities should take charge of the implementation process, the users should be at the center of that process and training and awareness programs should be integral to project implementation.*

Knowledge Management

There is a lack of effective dissemination of the knowledge gained and the lessons learned. “The Guidelines for Pedestrian and Bicycle Traffic in African Cities”, which was written and published by consultants after the project had ended, is the only comprehensive record of the various NMT activities. This is the primary source of written information.⁷⁵ The guidelines provide comprehensive information relating to the project and were produced in the format of a textbook. However, they include few details of the delivery of outputs in relation to the original program of activities.

The pilot interventions have generated a significant body of technical information on the planning and implementation of NMT measures. These studies show that simple cost effective measures can be implemented to relieve severe pressures on the existing urban transportation infrastructure. Important lessons were learned about how to involve users at all stages of the project cycle. Awareness, of the importance of considering the needs of non-motorized transport in the management of urban transport networks, increased amongst politicians, planners and engineers. Most of the project reports were produced by the consultants, either directly or under their close supervision. Important lessons have been learned about how to involve users at all stages of the project cycle, and about building capacity in local authorities. This information will be of enormous benefit to governments, local authorities, planners and engineers throughout SSA.

⁷⁴ Ibid.

⁷⁵ De Langen and Tembele, Op. cit.

Lesson #13: *Pilot projects have generated a significant amount of new knowledge and experience. It is important to disseminate this knowledge in an organized, effective and economic way to enable SSA urban transport professionals to acquire new knowledge and implement NMT programs in their own areas.*

9.4 User Participation

User participation was considered essential to the success of the NMT pilot projects. One of the core objectives of the program was to put the users at the center of the problem analysis, and intervention planning and selection process. Users were involved in all aspects of the pilot project implementation in four distinct user participation platforms (UPPs): Focus Group Discussions (FGDs) were used to identify the problems and make an inventory of these challenges.

- A. General User Platforms articulated and prioritized the user needs;
- B. Local User Platforms were actively involved in the planning and implementation of NMT interventions; and
- C. User Associations were to take a major role in the maintenance and operations of the built NMT infrastructure.

There were several challenges in making UP truly effective:

- A. Heterogeneity of the community made it difficult to sustain the users' interests in projects, unless there was a common problem and mutual trust;
- B. Historically set attitudes, regarding the fact that these were traditional government responsibilities, created reluctance by the users to participate;
- C. Continuity of participation was difficult to achieve; and
- D. Allowances paid to the participants in various UPPs created difficulties for assessing the motives for participation and continuity. However, when the practice of paying allowances stopped completely, there appeared to be better participation.

The GUPs and LUPs were disbanded after the implementation of the interventions and a short period of monitoring the impacts; their role was specifically to contribute to the NMT pilot project activities. They were effective in giving voice to the community. They made a major contribution to public awareness campaigns. Participants were initially unable to contribute significantly to designs due to lack of technical experience, but this improved substantially over time. The user platforms contributed positively to the outcome of the pilot interventions. Their confidence, pride and level of contribution increased as they gained experience. New ideas and initiatives started to emerge from group activities. It is therefore unfortunate that they could not continue in a form (perhaps simply as a lobby group) that would enable ongoing input to the management and improvement of NMT infrastructure.

Lesson #14: *Effective user participation is central to community empowerment and to the continuity of positive policies towards NMT users. If not properly structured, UP can be costly, cumbersome and frustrating. When structuring UP, it is important to strive for a balance between complete citizen controls of the projects on the one hand and total professional control on the other.*

Lesson #15: *Effective UP requires fully trained professional staffs who are sensitized to the importance of UP and truly believe that UP can make an effective contribution to the project interventions at all levels.*

Large-scale awareness campaigns can be costly and have limited or lasting impact without follow up and real activities. They may even influence the attitudes negatively. The best approach is NMT targeted campaigns combined with real interventions.

The concept of local authorities having to consult with community stakeholders in the planning and implementation of projects and the provision of NMT facilities represented a new way of thinking about mobility. Resistance to change from motorists and some engineering professionals was to be expected. A period of acclimatization for both NMT and motorized users alike would have been necessary. Therefore, there was need for sustained campaigns and lobbying before, during and after the project. Awareness and publicity campaigns could have been better deployed.

Lesson #16: *Large-scale public awareness campaigns are costly and have limited impacts without a proper follow up. The best approach is targeted awareness campaigns combined with NMT interventions, over the long term.*

9.5 Impact of NMT Infrastructure Interventions (Chapters 6 and 8)

Investment Analysis: Benefits and Costs

NMT investments were highly cost effective. B/C ratio varied from 1.75 for raised zebra crossings, 3.4 for walkway improvements and >4.0 for the Sosiani and Yombo River NMT bridges. There was one exception: the test with painted-only zebra crossings had a B/C ratio of 0 (no benefits at all).

Lesson #17: *The NMT infrastructure investments are highly cost effective.*

Traffic Safety

Painted zebra crossings, with no further speed reducing devices, were tested on Jogoo Road in Nairobi. Their effect on traffic safety turned out to be nil: drivers did not respect them in any way. In fact the accident hazards increased for pedestrians, as the painted crossings suggested fake-safety. The tests had been carried out using weak paint, which faded after a couple of months and was not maintained, to get rid of the fake-safety effect. Furthermore, when the road was later resealed, the zebra crossings were not re-painted.

On the other hand, the speed bumps on Nile Road in Nairobi achieved the reduction of maximum observed speeds from 62 km/h to 20 km/h (at the spot of the hump) and they contributed to increased levels of traffic safety. Raised zebra crossings on Temeke Road also achieved speed reduction and a substantial prevention of accidents.

Lesson #18: *Reduction in speeds can result in substantial increases in traffic safety; this can be achieved by simple traffic calming measures such as raised zebra crossings and/or speed bumps.*

In the first three months after the construction of “medians” in Eldoret, there was a 13 percent increase in cycling. However, subsequently bicycle use had started to go down due to increased traffic hazards. After one year, most of the increase in cycling over the Sosiani Bridge had disappeared, probably because the rest of the cycle route along Kisumu road was still too dangerous (see Section 8.6).

Lesson #19: *Traffic safety must be assured, over a sufficiently long network of routes and over the long-term, in order to retain any gains in cycling due to NMT improvements.*

Design and Implementation Issues

Although most of the equipment employed in the construction was not too expensive, smaller cities such as Eldoret could not even afford some of the low-cost implements such as hand rollers, hand sprayers, durable paint, concrete mixers, and moulds for culverts and spare parts for the machinery.

Lesson # 20: *Recognizing the fact that many local authorities in SSA have inadequate resources for construction and maintenance, the construction of NMT infrastructure inventions should make allowance for low cost equipment and should adopt labor-intensive methods.*

Soon after the construction, the curbstones at the traffic island test site, which align the carriageway at the road shoulder, were damaged by large trucks. This was quite probably the re-

sult of the unwillingness to slow down enough. The strength of the initially constructed curbstone was insufficient to survive shocks by heavy trucks. Constructing the carriage-way/shoulder separation past the islands, with T-blocks would have been better. Such a separation would be less vulnerable to damage and in addition, it commands more respect from drivers (fear for damage to vehicle tires) and therefore encourages lower speed.

Some poorly located crossing points were not optimally used. Many pedestrians continued to use shortcuts, even if it involved walking across difficult terrain or coming into conflict with motor vehicles.

Lesson #21: *The pilot project experience demonstrates that the design of some NMT infrastructure, while appearing to be straightforward on the surface can be extremely complex. This is due to the need to understand the behavior patterns of non-motorized and motorized transport users, and design the NMT infrastructure for lack of maintenance capability and very low levels of traffic law enforcement.*⁷⁶

After the implementation of the bicycle tracks along an urban corridor, Eldoret municipality was unable to enforce shopkeepers to leave the verandas in front of their shops free for use as a walkway. As a result, the pedestrians used the new “bicycle” track and almost all cyclists continued to use the MV carriageway, the new track being full of pedestrians.⁷⁷

Lesson #22: *Dedicated bicycle tracks, where there no dedicated pedestrian walkways, will not be successful. In fact, the bicycle tracks will quite literally be taken over by the pedestrians.*

On main corridors in Eldoret, the separation of NMT and MT by physical barriers showed good results. The carriageway was safer due to reduced MT/NMT conflicts, and dangerous overtaking maneuvers. On Uganda Road, the separation was combined with the redesign of the on street parking to accommodate a cycle lane, as well as the construction of bumps to reduce speeds. As a result, virtually all pedestrians moved from the carriageway to the footpath. In addition, the construction of improved Murram footpaths elsewhere on Kisumu Road resulted in more pedestrians using the footpaths, 86 percent of the pedestrians used the paths before the improvement and 98 percent, after the improvements. The upgrading or construction of new footpaths separated from the carriageway ranked highly as one of the more successful NMT interventions.

⁷⁶ Scott Wilson, Op. cit., p x.

⁷⁷ De Langen and Tembele, Op. cit., p. 190.

Lesson #23: *When cycling infrastructure is combined with appropriate pedestrian infrastructure, the NMT improvements are likely to be successful.*

Traffic Calming Instruments

The perception in Eldoret was that the pilot project interventions were quite successful. Eldoret Town Clerk stated, “The project was a resounding success. For example, it had positively impacted the accident situation. Accidents have reduced substantially. I would say that the project was 80 percent successful.”⁷⁸ (Cf. Table 6-6 Performance indicators for Eldoret)

Missing Links and NMT Only Infrastructure (Chapter 8.5 and 8.6)

The NMT Bridge over the Sosiani River and the improvement of the NMT track in Eldoret, proved to be very cost-effective. The estimated B/C ratio was 4.4, which translates into recouping investment on the route after one and a half year. Immediately after the new bridge opened, the number of cyclists on the Sosiani Bridge had increased by 100 percent.

The NMT Bridge over the Yombo River in Temeke provided a direct route from Yombo Island to the CBD of Temeke. The community enthusiastically supported the construction of this missing link by contributing free labor for its construction and subsequently for its repairs after heavy rains. The B/C ratio for this investment was 4.0 and the bridge was used intensively, with an ADT of 2,000 persons (95 percent pedestrians and 5 percent cyclists).

Lesson #24: *The NMT missing links and shortcuts are very cost effective and used intensively by low-income households.*

Maintenance and Security Aspects

On Uganda Road in Eldoret, concrete filled steel bollards were used to discourage motor vehicles from interfering with NMT infrastructure on road sections, at junctions and at crossings. Subsequently, some bollards were damaged but not repaired.

On Kisumu Road in Eldoret, pre-cast concrete curbs were laid along sections of the road, to prevent road and sidewalk pavement materials from dispersing. They also provided a drainage channel, making it difficult for the vehicles to encroach from the road. While curbs are easy to maintain (by manually knocking off the damaged section at the cement/sand mortar joint), the damaged curbs have not been repaired.

From the CBD towards the Kisumu Road Bridge, the interventions such as bumps, raised zebra crossings and central islands, were performing well. However, beyond the bridge on the road

⁷⁸ Scott Wilson, Op. cit., p. 18.

to the airport, a speed bump was damaged and pushed out of position, by heavy vehicles. Pre-cast concrete curbs and bollards installed to discourage parking on the pedestrian path were not fully effective. Furthermore, the open drains, constructed as part of the project, were full of silt.

Behind and in front of most speed humps and certain raised zebra crossings, potholes started to develop, mainly because of the drainage problems. However, this left the impression with some Temeke municipal engineers that humps would by definition cause potholes in the road. In addition, humps show deformation after 2-3 years, rendering them less effective. The conclusion was drawn from the tests that raised zebra crossings are superior to speed humps in terms of durability, constant performance over time, risk of pavement damage and maintenance requirements, and that therefore raised zebra crossings give more value for money, even if the initial investment is a bit higher.

Lesson #25: *NMT infrastructure design for SSA cities should be such that they require very little maintenance and materials used are sturdy with long life.*

Guardrails were cylindrical hollow pipes welded together and anchored into the ground. These were prone to theft as they find a ready market in the informal metalwork businesses.

Lesson #26: *The design of NMT facilities, which involve pipes, fittings and other metal fixtures, should be anchored and constructed in such a way that they are vandal-proof.*

Street Hawkers and Shopkeepers

Sosiani Pedestrian Bridge in Eldoret is used by pedestrians and cyclists and to some extent by the narrow gauge hand-pulled carts. Save for hawkers who took positions along the bridge to display their wares, the bridge was performing well. The redeeming factor is for the vendors to keep the bridge tidy.

In 2002, the paved pedestrian waiting areas, on Jogoo Road in Nairobi, were still in good condition. However, hawkers with their wares for sale had significantly undermined the usefulness of the paved areas for pedestrians. Encroachment by vendors onto NMT paths can be prevented only through increased collaboration between those in municipalities responsible for planning and constructing NMT infrastructure, and those managing the activities of the small-scale private sector.

Lesson #27: *If unrestrained, hawkers and vendors will encroach on to the newly built walkways and cycle tracks, resulting in reduced capacity and wasted NMT investment. It is necessary and important to regulate and control hawkers and vendors, especially in the central business districts.*

Solid concrete blocks were built onto the surface of Uganda Road in Eldoret to create a physical barrier between motor vehicles and NMT. They discouraged parking on the cycle path. This was successful because of municipality's development controls (forbidding the hawkers on pavements) through enforcement. Pedestrians could then walk freely on the sidewalk and the cyclists could use the newly created cycle path. The concrete blocks were largely maintenance free and vandal proof.

Lesson #28: *It is possible to control and regulate vendors and hawkers, thereby protecting the NMT investments.*

Properly designed bus bays have very positive impacts in improving traffic congestion and traffic safety. They also become economically attractive areas for kiosks and street trading. This is an excellent opportunity for private sector participation in NMT infrastructure facilities and it is an ideal opportunity for the local governments to negotiate with the minibus operators who are all from the private sector.

Lesson #29: *It is possible to incorporate proper space for vendors and hawkers in the design of bus bays, thus increasing public amenity as well as creating a source of revenue for the local governments.*

Sustainability of Interventions

Although the raised zebra crossings, constructed on Temeke Road in Temeke, were effective as crossing points for pedestrians, they had also become on-off passenger zones for dala dalas. The formation of potholes on the approach to crossings was a problem that required attention.

Many bollards and curbs were damaged or knocked out by motor vehicles. The dala dalas have been slowly encroaching back on to the shoulders.

The regional office of the Ministry of Works, in Morogoro, removed most of the test interventions, two years after construction, when the road in which they were constructed was fully rehabilitated. Interventions elsewhere in Morogoro remained: A Y-intersection changed to a T-junction to reduce conflicts, raised pedestrian crossings, bollards, solid concrete blocks and a bicycle parking facility. Save for the bicycle parking facilities, which had fallen into disrepair due to lack of use, the other interventions were still in reasonable condition and performing

well. The paint of zebra crossings had worn off. However, the drains were performing well and no pavement damage problems occurred.

The assessment done by the Bank in 2002 and various test results indicated that there would be problems of sustainability of the interventions (maintenance and renewal) as well as the potential for future NMT investments by the local authorities themselves. Damaged NMT infrastructure was neither being maintained nor being replaced. Is this a funding problem or one of different priorities? When some of the NMT Infrastructure made of metals (fence barriers, metal pots) was stolen or vandalized, they had not been replaced.

Lesson #30: *It is possible to design and implement appropriate NMT infrastructure facilities in SSA cities. However, these investments are not sustainable unless there is adequate maintenance and proper enforcement regarding encroachment by street traders and minibuss operators.*

In Morogoro, the PPU with the assistance of the national team persuaded two Bank-funded programs, the Integrated Road Project (IRP) and the Urban Sector Road Program (USRP), to include NMT infrastructure within their projects in Morogoro. The PPU and the national team assisted the two programs with designs of the NMT infrastructure. The outcome included separated pedestrian and cycle tracks, raised zebra crossings, dala dala stops, and open drains for separating motor vehicles from NMT. A substantial number of roads, under the USRP, have NMT infrastructure facilities and traffic calming aspects. The 3 kilometer long, Turiani Road was rebuilt with a 2x3 meter carriageway with open drains, a separate bi-directional cycle track and a walkway on one side of the road. The traffic condition has improved significantly in Morogoro in a well-balanced way between all modes.⁷⁹

Lesson #31: *Over the long-term, as experience and knowledge change the attitudes of the decision-makers and professionals. NMT facilities will become an integral part of urban transport planning in SSA. However, this requires a long-term commitment from the World Bank and other donor agencies to sustain the efforts in the planning and implementation NMT infrastructure.*⁸⁰

Increasing the Ownership and Use of Bicycles

Traffic counts in Eldoret, taken a year later on both routes, indicated that half the initial modal shift towards cycling faded away. The new cyclists on the NMT-only route remained but those on Kisumu road slowly disappeared. The renewed reduction in the number of cyclists on Kisumu road appeared to be quite logical because the route still had a number of other dangerous

⁷⁹ De Langen, Op. cit.

⁸⁰ Marius de Langen, Test Interventions in Temeke and Morogoro, Long Term Impact Evaluation, Report to the World Bank, September 2003.

parts, which remained unchanged: solving one dangerous spot does not make the entire route safe. The initial optimism of those that resumed cycling probably died out with the renewed experience of how dangerous the other sections of the route still were. This trend was evident in Eldoret as a whole. Bicycle ownership is still high, with more than 50 percent of all households having one or more bicycles. Cycling used to be important. At the time of monitoring, its modal share was around 12 percent of ADT but it could still go down because of the increased traffic accident risks.

Lesson #32: *Traffic safety, both real and perceived, is pre-requisite to increase cycling in SSA cities, in addition to introducing avenues for the low-income households to own a bicycle.*

Providing incentives to employers to establish bicycle credit or savings schemes was considered. However, the market conditions and business attitudes were unfavorable to credits pre-financed by employers for their employees. However, bicycle credit purchases through employee savings schemes were more successful. In Eldoret, where many successful savings societies have already existed for decades, the Raymonds Savings and Credit Cooperative Organization of Raymond Textile Factory, (a large private firm) started a bicycle credit scheme for its members. SACCO offered 300 bicycles to its members on a credit purchase plan and all the bicycles were sold within two weeks.

Lesson #33: *The traditional financial institutions being not forthcoming in this field, the World Bank should consider a program of micro-loans through employer/employee institutions, and other mechanisms for larger scale programs of making bicycles available on credit.*

The PPU attempted to introduce promotional sale of bicycles to women (of women's bicycles) and to children entering secondary schools. This scheme, giving a 15-20 percent discount, was quite popular in Morogoro. The response to the scheme also showed that the price elasticity of the bicycles is high: a small price discount creates a significant increase in the number of buyers. The authorities could consider measures such as exempting bicycles from import taxes or VAT.

Lesson #34: *In most SSA cities, there is a large unfilled potential for cycling by women. Promotion of cycling by women and teaching cycling to secondary school students, particularly to women, should be integral parts of Bank urban transport projects in SSA.*

"Bicycles for Hire" business in Morogoro is thriving, with ± 200 micro-entrepreneurs with approximately 1,500 bicycles. The bicycles are rented on an hourly, daily or weekly basis. They

capture market share of ± 6 percent of all daily trips, roughly about half the market share of the minibus trips.

Lesson #35: *As a positive step towards more urban cycling in SSA, urban transport projects should include mechanisms to establish "bicycle for hire" micro-enterprises.*

9.6 Private Sector Participation (Chapter 7)

The businesses in Nairobi have traditionally provided the bollards to prevent parking on paved areas in front of shops, thus creating unobstructed walkways.

Lesson #36: *Small-scale opportunities exist in some commercial areas for private sector participation in the provision of dedicated walkways. Such private sector partnerships should become part of the urban transport projects in SSA.*

The community (private sector) contributed volunteer labor for the construction of Yombo River Bridges I and II and subsequently for the repairs after very heavy rains in Temeke.

Lesson #37: *In making strategic NMT investments for missing links and NMT only bridges, it is important to assure that the community and the private sector are partners in development, at the same time recognizing the limited capacity of low-income households to contribute cash rather than labor.*

9.7 Future Research

Specific areas of research which could benefit NMT planners are:

- A. Identification of appropriate and sustainable construction materials in different countries which are easily available and require very low maintenance;
- B. Construction materials for NMT infrastructure that are highly visible to drivers and yet require low maintenance;
- C. Speed reduction and appropriate crossing point design on *arterial* roads;
- D. Appropriate traffic calming measures for different classes of roads;
- E. Criteria for locating the raised zebra crossings since they were not all well used by pedestrians⁸¹;
- F. Optimal spacing of speed bumps and location criteria for raised zebra crossings;

⁸¹ Some concerns have however been raised by some that zebra crossings do not necessarily create a safe walking environment for pedestrians.

- G. Design concepts and criteria, for speed bumps and raised zebra crossings, which can eliminate the formation of potholes at the approaches; and
- H. Design standards for appropriate infrastructure for NMT such as pushcarts in urban areas.

9.8 Institutional Issues for Future Projects

The assessment of the NMT pilot interventions has raised a number of key issues that could be addressed in future interventions⁸²:

- A. Is it feasible to expect technical staff within local authorities in SSA to deal with the complexities of designing effective NMT infrastructure, even if guidelines are available in the form of a manual? Alternatively, will it be necessary to provide permanent technical assistance either from the private sector or from the central government?
- B. Are transportation planners and engineers, used to traditional approaches, willing to give equal priority to NMT and motorized transport?
- C. What is an appropriate level of user participation, which is sustainable within the resource constraints experienced by most local authorities? How can a balance be attained between the need to involve users and the need for local authorities to exercise proper control of activities and the outcomes?
- D. Are local authorities willing to promote and facilitate direct user financing of NMT infrastructure in exchange for greater accountability? Are users willing to take up this challenge?
- E. In order to answer these questions it is likely that it will be necessary to work with a much wider number of local authorities in SSA.

9.9 Future SSATP Activities

Further activities that could be undertaken to consolidate and further develop the achievements of the NMT pilot projects include:

- A. Undertake a survey of standard NMT infrastructure design details already used by local authorities in SSA. Assess the potential usefulness of consolidating these designs and the experiences of the pilot projects into a design manual for NMT infrastructure. Analyze the suitability of these designs in relation to the lessons learned on the pilot projects.

⁸² Scott Wilson, *Op. cit.*, pp. xii-xiii and pp. 54-55.

- B. Establish the need for a manual of standard designs that could be used widely in the region. Establish the appropriate level of sophistication for such a manual.
- C. Encourage a wider awareness and higher profile for NMT issues by establishing a Challenge Fund, which would enable committed local authorities in SSA to access funds to develop their own capacity for addressing the needs of NMT and to long-term capacity development in their own organizations. Funds would be allocated to those demonstrating commitment to the needs of NMT users.

10 REFERENCES

- Abebe, K. Poverty in Addis Ababa, in *Social Dimensions of Poverty*, (Ed). Meheret Ayalew, Addis Ababa. June 2001.
- Abeille, M. and Duprez, F. Dysfonctionnements du système des transports urbains d'Abidjan, Actes de CODATU 9, April 2000.
- Addis Ababa City Administration, Draft Five-Year Development Strategy. (Amharic version), Addis Ababa, October 1998.
- Addo, S.T. Urban Transport in Ghana and Africa: Problems and Solutions, Ghana Social Science Journal, 1:2, 2002.
- Adesanya, A., How dependable and sustainable are the low cost public transport options in meeting the mobility needs in Nigerian urban centers?, CODATU 10, November 2002.
- Adesanya, A.O. and Adeniji, S.A. Sustaining urban public transport in Nigeria: Critical issues and remedies, CODATU 8, September 1998.
- Adoléhoumé, A.P. La protection des usagers vulnérables de la circulation dans les villes africaines: étude de cas des points noirs à Ouagadougou, Actes de CODATU 10, November 2002.
- Akakpo, A.M. The role of the city of Lomé in urban transport, CODATU 8, September 1998.
- Alder, G. Tackling Poverty in Nairobi's Informal Settlements: Developing an Institutional Strategy, Environment and Urbanization, 7:2, 1995.
- Aloko-N'Guessan, J., Taxis Woro-woro à Abidjan et résonance communale à Koumassi, Actes de CODATU 10, November 2002.
- Analyse du Système de déplacement à Ouagadougou- 1993, Ouagadougou, Burkina Faso, INRETS, Paris, 2000.
- Baguley, C., Pedestrian Road Safety Studies in Harare and Ouagadougou, 11^{ème} réunion du comité d'orientation, April 2001.
- Bamas, S., Ouagadougou: Entre 2 roues et voitures particulières, Actes de CODATU 8, September 1998.
- Bamas, S., Vers la mise en place laborieuse d'une politique de transport urbain à Ouagadougou: quels enseignements pour les villes africaines ?, Actes de CODATU 8, September 1998.
- Banyikwa, W. S., Urban Passenger Transport Problems in Dar es Salaam, Tanzania, African Urban Quarterly, 3:1-2, 1988.
- Barrett, R., A policy program and strategy for urban transport in the second African transport and communications decade, in *Les transports dans les villes du Sud ; la recherche de solutions durables*, Kathala, CODATU, 1994.

- Barrett, R., Role of the World Bank in the Development of Urban Transport in Sub-Saharan Africa, SSATP Working Paper No. 1, 1993.
- Benmaamar, M. and al, Urban Transport Services in SSA: Recommendations for Reform in Uganda, Transportation Research Record 1812.
- Bi Nagoné, Z. et Marteau, J. F., Points et perspectives des transports urbains à Abidjan-Actes du SITRASS 5, Novembre 1999.
- Bi Nagoné, Z., Précarité et mobilité à Abidjan, Actes de CODATU 10, Novembre 2002.
- Boupda, E., L'organisation des transports informels dans l'agglomération de Douala, Actes du SITRASS 6, November 2001.
- Bultynck, P., Transport 1998-2002: Strategic Development Plan, SSATP Working Paper No. 35, 1998.
- Bultynck, P., Plan de développement stratégique du transport urbain 1998-2002 SSATP Working Paper No.35. Septembre 1998
- Central Statistical Authority (CSA), Report on The 1998 Welfare Monitoring Survey, Statistical Bulletin 224, Addis Ababa, November 1994.
- Cisse, C., The role of the city of Dakar in urban transport policy, CODATU 8, September 1998.
- Clément, C., Représentations spatiales, mobilités urbaines quotidiennes et migrations à Niamey, Niger, Actes de CODATU 8, Septembre 1998.
- County Surveyors Society, *Traffic Calming in Practice*, Landor Publishing Ltd., 1994.
- CSA, Report 1995/96 Household Incomes, Consumption And Expenditure Survey, Volume I, Statistical Abstract 170, Addis Ababa. January 1997.
- Cusset, J. M., Analyse du système de déplacement à Ouagadougou, INRETS, 1993.
- Cusset, J-M. Accessibility to urban services and mobility needs of peripheral population: Case of Ouagadougou, Actes de CODATU 8, September 1998.
- Cusset, J-M. and Sirpe G. La mobilité apportée par le système deux roues: le cas de Ouagadougou in *Les transports dans les villes du Sud; la recherche de solutions durables*, Kathala, CODATU, 1994.
- Cusset, J-M. et al, Les besoins de mobilité et leur expression dans les arbitrages urbains à Ouagadougou, LET-CEDRES-INRETS, Paris, 1996.
- Cusset, J-M., Low Cost Mobility in West African cities, Proceedings of the Expert Group Meeting on Low Cost Mobility in African Cities, UNESCO-IHE Delft, Delft, 2000.
- Da Matha Sant'Anna M. A., Mobilité, pauvreté et environnement: Convergences et contradictions: Cas de Cotonou, Actes de CODATU 10, Novembre 2002.

- Dabilgov, V., Role of the city of Ouagadougou in urban transport policy, CODATU 8, September 1998. *Compte-Rendu de la Conférence et première rencontre du comité d'orientation*, Décembre 2001.
- De Langen, M. and Tembele, R., Guidelines for Pedestrian and Bicycle Traffic in African Cities, SSATP NMT Studies, Report 2, December 1994
- De Langen, M. and Tembele, R., Productive and Liveable Cities: Guidelines for Pedestrian and Bicycle Traffic in African Cities, Version 1.3, Balkema Publishers, Lisse, 411 p., ISBN 90-5809-199-6. The Netherlands, 2001.
- De Langen, M., Economic Justification of Urban NMT Infrastructure, 3rd Tanzania National Seminar on Urban Mobility, Dar es salaam, December 1998.
- De Langen, M., Test Interventions Implemented in Tanzania, Dar es Salaam (Temeke) and Morogoro, Long-Term Impact Evaluation, A SSATP Report to the World Bank, September 2003.
- De Langen, M., Urban Mobility and NMT in Sub-Saharan Africa, Transportation Research Board, Washington, DC, January 1999.
- Diaz Olvera, L., and Plat, D. Mobilités quotidiennes à Ouagadougou, *Cahier des Sciences Humaines*, 32:2, 1996.
- Diaz Olvera, L., Enquête sur la mobilité, le transport et les services urbains à Dakar : Mobilité quotidienne et pauvreté, *Méthodologie et résultats*, LET, Octobre 2002.
- Diaz Olvera, L. et al, Dépenses de transport des ménages dans les villes d'Afrique subsaharienne, *Actes de CODATU 9*, Avril 2000.
- Diaz Olvera, L. et al, Effets du revenu et du lieu de résidence sur l'accès à la ville: cas de Niamey, *LET*, Lyon, France, 1999.
- Diaz Olvera, L. et al, Étalement urbain et mobilité à Niamey, *Actes de CODATU 9*, Avril 2000.
- Diaz Olvera, L. et al, La voiture au quotidien : réalités contrastées, rêve partagé, *Actes de CODATU 8*, Septembre 1998.
- Diaz Olvera, L. et al, Les déterminants de la mobilité urbaine : une comparaison entre Bamako et Ouagadougou, *Actes de CODATU 7*, Février 1996.
- Diaz Olvera, L. et al, Les multiples visages de la mobilité féminine dans les villes d'Afrique subsaharienne, *Actes de CODATU 8*, Septembre 1998.
- Diaz Olvera, L. et al, Mobilité quotidienne des citadins à faibles ressources : Les enseignements de Ouagadougou, *LET*, Lyon, France, 1999.
- Diaz Olvera, L. et al, Mobilité quotidienne des ménages dans les villes d'Afrique subsaharienne, *LET*, Lyon, France, 1998.
- Diaz Olvera, L. et al, Mobilité quotidienne et pauvreté dans les villes d'Afrique subsaharienne : Les enseignements de Ouagadougou, *LET*, Lyon, France, 1998.

- Diaz Olvera, L. et al, Vers une ville à deux vitesses ? Transports et accès aux équipements à Dar es Salaam, LET, Lyon, France, 1998.
- Diaz Olvera, L. et al, Villes africaines au quotidien, Études et Recherches, No. 9, LET, Lyon, France, 1993.
- Diaz Olvera, L. et al, Villes africaines au quotidien, LET, Lyon, France, 1998.
- Diaz Olvera, L. et al, Walking and poverty in Sub-Saharan Africa, CODATU 10, November 2002.
- Dille, B., Les kabu kabu de Konni, facteurs de développement ou solution temporaire - Actes de CODATU 8, Septembre 1998.
- Diouf, I., Financement de micro-entreprises de transport public urbain : le cas de Dakar (Sénégal), 11^{ème} réunion du comité d'orientation, Avril 2001.
- Djenapo, M. et Kone, D., Analyse socio-économique de la tarification des transports urbains à Bamako, Actes du SITRASS 6, Novembre 2001.
- Duprez, F., The social costs of the Abidjan's urban transport system, CODATU 10, November 2002.
- Dutch Ministry of Transport, Public Works and Water Management, the Hague, Netherlands, Cities Make Room for Cyclists, August 1995.
- Eboumbou-Jemba, C. Développement urbain, transport et énergie à Douala, Cameroun, Avril 2000.
- Eboumbou-Jemba, C. Transports Urbains et pauvreté dans une grande métropole de l'Afrique Centrale: Cas de Doula au Cameroun, Actes du SITRASS 6, Novembre 2001.
- ECA, Urban Mobility and Non-Motorized Transport in Kenya, December 1998.
- Economic Commission for Africa (ECA), Nairobi Action Plan for Urban Mobility and Non-Motorized Transport, December 1994.
- Ekwalla, D. et Bouma, E. Transport pluriel et productivité : cas de la ville de Douala au Cameroun, Actes de CODATU 10, Novembre 2002.
- Ewing, R. "Transportation Service Standards - As If People Matter," Transportation Research Record 1400, (www.trb.org).
- Fomba, B. and Guiro, S. Les transports urbains à Bamako, Actes de la CODATU 8, Septembre 1998.
- Gachewa, S., Proceedings of the Workshop on User Participation in Urban Mobility and NMT in Nairobi, Jogoo Road Corridor, Nairobi, June 1997.
- Gachewa, S., Public Awareness and Education Intervention Campaigns, Jogoo Road, Nairobi, SSATP NMT Report, Nairobi, June 1997.
- Gannon, C. and Liu, Z., Poverty and Transport, World Bank, 1997.

Gbaguidi, G. D. Rôle de la circonscription urbaine de Cotonou dans les transports urbains, Actes de CODATU 8, Septembre 1998.

Getachew, M., The Effects Of Rapid Population Growth On Socio-Economic Development in *Explaining Economic Growth and Development in Ethiopia*, The Tenth Annual Conference On The Ethiopia Economy, Addis Ababa, November 2001.

Godard, X. and Diaz Olvera, L., Poverty and Urban Transport: French experience in Developing Countries, TWTD, World Bank, September 2000.

Godard, X. and Teurnier, P., Les transports urbains en Afrique à l'heure de l'ajustement, redéfinir le service public, INRETS, Paris, 1992.

Godard, X., Les systèmes de transports urbains en ASS ou la résistance face aux tentatives de réforme institutionnelle, Actes du SITRASS 5, Novembre 1999.

Godard, X., Les transports dans les villes du sud; la recherche de solutions durables, Kathala, CODATU, 1994.

Godard, X., Mobilité urbaine et pauvreté : l'expérience ouest africaine, Actes de CODATU 8, Septembre 1998.

Godard, X. and Kane, C., Mobility conditions of the urban Poor: Diagnosis and condition for actions in Dakar, International Forum on Urban Poverty, Nairobi, 1999.

Government of Ethiopia (GOE), Survey of the Ethiopian Economy, Ministry of Economic Development and Cooperation, Addis Ababa. 1998.

GOE, Urban Transport and Road Network, Office for the Revision of the Addis Ababa Master Plan, Addis Ababa. January 2000.

Government of Kenya (GOK), Economic Growth and Poverty Reduction, Government Printer, Nairobi, 2002.

GOK, 8th National Development Plan 1997-2001, Nairobi, Government Printer, 1997.

GOK, 9th National Development Plan 2002-2008, Government Printer, 2002.

GOK, Interim Poverty Reduction Strategy Paper 2000-2003, Government Printer, Nairobi, 2000.

GOK, Kenya Municipal Road Management Study, Road Inventory For City Of Nairobi, Ministry Of Local Government, Nairobi, October 1992.

GOK, National Poverty Eradication Plan to 2015. Nairobi, Government Printer. 1999.

GOK, Poverty Reduction Strategy Paper 2000 -2004, Nairobi, Government Printer. 2000.

GOK, Strategic Plan for Roads Sector, Nairobi, Government Printer, March 1997.

Government of Ghana, 2000 Population and Housing Census Reports, Statistical Services, Accra, 2002.

- Halla, F., Transport-related pollution and investments required to minimize it in Dar-Es-Salaam City, CODATU 9, April 2000.
- Hamdou-Rabby, W., Urban mobility and emissions: towards accurate standards for sub-saharan africa-District of Bamako, 11^{ème} Réunion du comité d'orientation, April 2001.
- Hook, W., Economic Importance of Non-Motorized Transport, Transportation Research Record 1487.
- Hop, G. and al, A Bus-way on Jogoo Road, Nairobi, CODATU 9, April 2000.
- Howe, J. and Bryceson, D., Poverty and urban transport in East Africa: Review of Research and Dutch Donor Experience, (Étude Mobilité Urbaine et Transport Non Motorisé des Ménages les Plus Pauvres-PUTEA), 1993-1999 SSATP, A Report prepared for the World Bank, December 2000.
- INRETS, Analyse du système de déplacement à Ouagadougou - 1993, Paris, 2000.
- Jacobs, G.D and al, A Comparison of Bus Operations in Cities of Developed and Developing Countries, Traffic Engineering and Control, TRL, Crowthorne, UK, 1979.
- Jean-Michel Cusset et al, Les transports urbains non motorisés au Burkina Faso, LET-CEDRES-INRETS, Paris, 1995.
- Kane, C. and Godard, X., Performances des modes de transport et satisfaction des besoins des pauvres, cas de Dakar, Actes du SITRASS 6, Novembre 2001.
- Kasuku, S. O., Provision of Pedestrian Transport facilities in Nairobi City: The Case of Jogoo Corridor, M.A. Thesis, University of Nairobi. 2001.
- Kienle, W., Mobility crisis in Nigeria: The challenge of motorcycling, CODATU 7, February 1996.
- Kisisa, I., Pilot Projects on Urban Mobility and Non-Motorized Transport, Traffic Calming Experiments in Tanzania, Prepared for the National Seminar, Dar es Salaam, December 1998.
- Koster, J. H. and de Langen, M., Proceedings of the Expert Group Meeting on Low-cost Mobility in African Cities - World Bank seminar, UNESCO-IHE, Delft, 2001.
- Koster, J.H. and Gachewa, S., Performance Assessment of Privatized and De-Regulated Public Transport System, Transportation Research Board, Washington D.C. January 1999.
- Koster, J.H. and Hop, G., Formal and Informal Public Transport Performance Assessment: Nairobi Case Study, CODATU 9, April 2000.
- Kouane, P. Y., Expérience de redressement d'une entreprise de transport collectif urbain en Afrique subsaharienne : le cas de la SOTRA à Abidjan, Actes de CODATU 8, Septembre 1998.
- Kumar A. and al, What Works in Private Provision of Bus Transport Services-Case Study of Accra and Addis Ababa, April 2003.

- Kwakye, E. A., Institutional Restructuring for Road Safety Improvement in Ghana, 11th Meeting of the Policy Committee, April 2001.
- Lia, B. G. and Kouakou-Kouakou, R., Le financement privé d'infrastructures publiques de transport en Côte d'Ivoire - Actes du SITRASS 6, Novembre 2001.
- Mairura, O. and al, Nairobi Household and Corridor Survey Analysis, SSATP NMT Report, 1994.
- Malou, N., Le besoin de mobilité à Bamako, cas des quartiers de Banconini et Sokordji, INRETS-SITRASS, Paris, 1996.
- Masimilien Bamas, S.M., Le rôle des 2 roues dans les extensions urbaines de Ouagadougou : quels enseignements pour les villes africaines, Actes de CODATU 7, Février 1996.
- Massonsa, W.M., Problématique des transports urbains à Kinshasa - Enjeu pour la lutte contre la pauvreté par la mobilité, Actes de CODATU 10, Novembre 2002.
- Maunder, D.A.C. and al, Sustainable livelihoods, mobility and activity patterns in Zimbabwe and Uganda, Actes de CODATU 10, November 2002.
- Mbara, T.C. and Maunder, D.A.C., The initial effects of introducing commuter omnibus services in Harare, Zimbabwe, Actes de CODATU 7, February 1996.
- Mbara, T.C., Urban transport challenges of developing countries: the case of Harare, Actes de CODATU 9, April 2000.
- Mbonde, M., Transports urbains à Bangui, 11^{ème} réunion du comité d'orientation, Avril 2001.
- Minard, V., Mobilité et coût du déplacement, ENTPE, 1999.
- Mosi, J. and Mosi, D., Urban Mobility and Non-Motorized Transport, Phase II, Pilot Project in Tanzania. Bicycle Promotion in Morogoro Municipality, Prepared for National Seminar, Dar es Salaam, 15-16 December 1998.
- Nairobi Action Plan for Mobility and NMT, Report No. 12, SSATP NMT Study, November 1994.
- Ngabmen, H. et Godard, X., Indicateurs sur les systèmes de transport urbain en Afrique subsaharienne : une nouvelle tentative, Actes de CODATU 8, Septembre 1998.
- Ngabmen, H. et Godard, X., L'expérience des taxi-motos en Afrique de l'Ouest: à la croisée des logiques économiques, sociales et environnementales, Actes de CODATU 8, Septembre 1998.
- Ngabmen, H., Broutin, C. and Essomba Eloundou, A., Libéralisation de l'exploitation des transports collectifs à Douala et Yaoundé - 11^{ème} Réunion du comité d'orientation, Avril 2001.
- Oloude, B. Transport urbain collectif à Cotonou : vers le développement de la micro-entreprise, 11^{ème} Réunion du comité d'orientation, Avril 2001.
- Omwenga M. and al., Preliminary Assessment of NMT Potential in Eldoret, SSATP NMT Report No. 15, December 1994.

- Omwenga, M, and Malombe, J., Problems and Prospects for Urban Non-motorized Transport in Sub-Saharan Africa, The Case of Nairobi, 7th Velo-City Conference, September 1993.
- Omwenga, M. et al, Preliminary Assessment of NMT Potential in Eldoret, Report No. 15, December 1994.
- Ongolo-Zogo, V., Quel modèle de concession des réseaux de transport dans les capitales africaines : le cas de Yaoundé, Actes de CODATU 10, Novembre 2002.
- Ongolo-Zogo, V., Signification, Bilan et perspectives de la concession des lignes de transports urbains à Yaoundé, Actes du SITRASS 5, Novembre 1999.
- Ongolo-Zogo. V., Plaidoyer pour une autre politique de transport urbain : incitation/régulation, Actes de CODATU 8, Septembre 1998.
- Opiyo T. and de Langen, M., Planning and Design of a Pilot Pedestrian and Bicycle Track Network in Nairobi, Kenya, CODATU 8, September 1998.
- Opiyo, T., Urban Road Safety Experiments in NMT in Kenya and Tanzania, Road Safety Experiments in Sub-Saharan Africa, Urban and Transport and Mobility Training Program for Eastern and Southern Africa, Addis Ababa, May 2002.
- Oyesiku, O. K and Odufuwa, B.O., Gender perspectives in travel behaviour of motorcycle passengers in Nigerian intermediate cities, CODATU 10, November 2002.
- Oyesiku, O.K., A Policy framework for urban motorcycle public transport system in Nigerian cities, Actes de CODATU 10, November 2002.
- Oyesiku, O.K., Transport-related pollution perspectives of the use of three-wheelers mode of public transportation in the Lagos metropolis, Actes de CODATU 9, April 2000.
- Pochet, P. et al, Les transports urbains non motorisés en Afrique subsaharienne, LET-INRETS, Paris, 1995.
- Post Buckley International, Nairobi Long Term Transport Study, In Association with Kaburu Okello and Partners, Ministry of Local Authorities, July 1998.
- Post Buckley International, Nairobi Long Term Transport Study, Ministry of Local Authorities, Nairobi. 1998.
- Ribbens, H., Strategies to Promote the safety of Vulnerable Road Users in Developing Countries: South African Experience, Transportation Research Record 1846.
- Rwebangira T. and Nguma, J., Dar es Salaam Action Plan for Urban Mobility and NMT, SSATP NMT Report No.14, 1994.
- Rwebangira, T. and de Langen, M., Urban Road Design Standards: NMT Elements, Transportation Research Board, Washington, DC, January 1999.
- Rwebangira, T. and Nguma J., Nairobi Household and Corridor Survey and Analysis, SSATP NMT Report 11, December 1994.

Sambali, G. I. and al., Determinants of Cycling in Medium and Large Cities in SSA, Proceedings of the World Conference on Transport Research, Antwerp, 1998.

Sambali, G.I., Pilot Projects on Urban Mobility and Non-Motorized Transport: Urban Travel Situation in Morogoro Municipality, Prepared for the National Seminar on Bicycle Promotion, August 1999.

Sanwidi, S.D., Organisation et exploitation des transports en commun : Ouagadougou à la croisée des chemins, Actes du SITRASS 6, Novembre 2001.

Scott Wilson, Assessment of the Non-Motorized Transport Program in Kenya and Tanzania, SSATP Working Paper No. 71, November 2002.

Segbor, P.K., Quels transports urbains à Lomé en l'an 2000, Actes de CODATU 8, Septembre 1998.

Sethi, K. and Bhandari, A., Impact of planned improvements in public transport on the urban poor in Lagos - Actes de CODATU 7, February 1996.

Silcock R., Ethiopia Sectoral Road Safety Programme: Study Report. European Commission, European Development Fund. Unpublished Project 7.Et.089 Pr/Int/694/01. Ethiopian Roads Authority, Addis Ababa. 2001.

SITRASS, Étude régionale sur l'organisation, le financement et la rentabilité des microentreprises de transport urbain en Afrique subsaharienne : Cas des Gbakas à Abidjan, Document de travail SSATP No. 45, Mai 2000.

SITRASS, Étude régionale sur l'organisation, le financement et la rentabilité des microentreprises de transport urbain en Afrique subsaharienne : Cas de Bamako, Document de travail SSATP No. 49, Novembre 2000.

SITRASS, Étude régionale sur l'organisation, le financement et la rentabilité des microentreprises de transport urbain en Afrique subsaharienne : Cas de Nairobi, Document de travail SSATP No. 50, Décembre 2000.

SITRASS, Étude régionale sur l'organisation, le financement et la rentabilité des microentreprises de transport urbain en Afrique subsaharienne : Cas de Harare, Document de travail SSATP No. 53, Janvier 2001.

SITRASS, Profitabilité et financement des microentreprises de transport en commun en Afrique subsaharienne : Un aperçu de l'étude régionale, Document de travail SSATP No. 54, Mars 2001.

SSATP Working Paper No. 36, Rencontre du Comité d'orientation au Cap, Afrique du Sud, Octobre 1998.

SSATP Working Paper No. 38, Séminaire de Dakar des 17-18 décembre 1998 sur les transports urbains et la qualité de l'air à Dakar : Compte rendu, Février 1999.

SSATP Working Paper No. 41, Études sur la qualité de l'air en milieu urbain : Cas de Dakar et Ouagadougou, Rapports finaux, Septembre 1999.

SSATP Working Paper No. 57, Onzième rencontre du Comité d'orientation, Accra, Ghana : Compte-rendu, Avril 2001

SSATP Working Paper No. 58, Gestion des transports urbains : Cycle de formation à la gestion et la maintenance des équipements municipaux, Abidjan, Juillet 2000.

SSATP Working Paper No. 6, Conférence nationale sur l'élimination progressive de l'essence : contenant du plomb au Nigéria, Abuja, Novembre 2001.

SSATP Working Paper No. 69, Proceedings of the Annual SSATP Conference on Mobility, September 2002.

SSATP, Eldoret Mobility Plan, NMT Study, February. 1998.

SSATP, Report on Short Course: Training for Kenyan Engineers and Planners, Kenya National Team, 1999.

SSATP, Terms of Reference, Phase 2, Part I, Appendix A, Urban Transport Component, Kenya and Tanzania. 1995.

SSATP, Terms of Reference, Work Plan and Budget, Phase 2, Part II, SSATP Urban Transport Component, Non-Motorized Urban Transport, Kenya and Tanzania, 1998.

SSATP, Test Intervention Report Series: Urban NMT and Traffic Calming, Traffic Calming along Temeke Street, Urban Transport Component, December 1998.

SSATP, Transport User Perspectives In Nairobi: The Vulnerable Groups, Report 9, NMT Study, November 1994.

SSATP, Transports collectifs en Afrique : Synthèse de l'étude régionale, Mars 2001

Tamakloe, E.K.A, Transport: The Future of our Cities, Proceedings of the Ghana Academy of Arts and Sciences, Volume XXX, Accra, pp.31-37 1993.

Tatiétsé T. et A. Bidja, Impact du parc automobile et du linéaire de voirie sur la mobilité urbaine à Yaoundé, Actes de CODATU 10, Novembre 2002.

Tchassama, B., Transports publics et sécurité routière à Lomé, Actes de CODATU 10, Novembre 2002.

Teurnier, P., L'expérience et les perspectives de la complémentarité intermodale dans le réseau de service public de transport urbain à Dakar au Sénégal, Actes de CODATU 7, Février 1996.

Teurnier, P., Révision du cadre institutionnel des transports urbains à Dakar : un processus délicat, Actes du SITRASS 5, Novembre 1999.

TNBS and Oxford Policy Management Ltd., Developing a Poverty Base Line in Tanzania, Dar Es Salaam, May 2000.

Transport Research Laboratory (TRL), Basic Design Study Report on Dar Es Salaam Road Development Project, The Stationery Office, London. 1996.

TRL, Ethiopia Sectoral Road Safety Program: Study Report, Unpublished Project Report, Ethiopian Roads Authority, Addis Ababa. 2001.

TRL, Road Accidents Great Britain: The 1999 Casualty Report, Crowthorne, 2000.

TRL, Scoping Study: Urban Mobility in Three Cities, SSATP Working Paper No. 70, October 2002.

UNCHS, Urbanizing World: Global Report On Human Settlements. Hs/382/95e United Nations Human Settlements Program (Un-Habitat), Nairobi. 1996.

Van Schalkwyk, I., Testing, Evaluation and Application of Standards to Road safety Devices in South Africa, Transportation Research Circular E-C038.

Vijayakumar, S. and Jacobs , G. D., Factors Affecting the Use of Public Transport in Cities in Developed and Developing Countries, Traffic Engineering And Control, U.K. 1983.

Wilson, S. K., Road Infrastructure Policies in Kenya: Historical and Current Challenges, Kenya Institute of Public Policy research and analysis (KIPPRA) Working Paper Number 1, Nairobi. 2001.

Yatta, F., Secteur public et/ou secteur privé ? Recherche de solutions durables au problème des déplacements urbains : le cas de Niamey, Actes de CODATU 7, Février 1996.

Ziracha, R. and Mbara, T., Introduction of an integrated rail/bus commuter system in Zimbabwe-political gimmick or sustainable option? Actes de CODATU 10, November 2002.

11 ELECTRONIC SOURCES

African cities, planning for non-motorized transport

www.ibike.org/africa.htm
www.ibike.org/library/africa.htm
www.ibike.org/bibliography/bike-policy.htm
www.itdp.org/PR/bogota_model.html
www.itdp.org/tra/tra_4/read/tra4.pdf
www.mobility.de/brm/plan/replogle/tp_rep4.htm
www.transport.gov.za/library/docs/codatu/techprog.html
www.trb.org
www.worldbank.org/afr/ssatp/ut.htm
www.worldbank.org/transport/publicat/td-ut4.htm
www.scp-mobility.org
www.unesco-ihe.org

African cities, non-motorized transport design

www.ibike.org/engineering
www.uctc.net/scripts/countdown.pl?713.pdf
www.unhabitat.org/HD/hdv4n2/region.htm
www.urbanbikes.net/urb_transport/CHAPTER%20THREE.pdf
www.vtpi.org/tdm/tdm75.htm
www.worldbank.org/poverty/strategies/chapters/transport/trtn0509.pdf
www.scp-mobility.org

African cities, financing non-motorized transport

http://csdngo.igc.org/transport/tran_statement_intersessional2001.htm
http://mercyworldorg.ozstaging.com/projects/mgc/2004/pdfs/8-csd_report-from-africa.pdf
www.cycling.nl/download/publications/sign_non_mot_transport.pdf
www.itdp.org/read/AR_2002.pdf
www.transport.gov.za/library/docs/codatu/techprog.html
www.unhabitat.org/HD/hdv4n2/region.htm
www.worldbank.org/afr/ssatp/Working%20Papers/SSATPWP01.pdf
www.worldbank.org/poverty/strategies/chapters/transport/trtn0509.pdf

African cities, planning walkways

http://econ.worldbank.org/files/17956_WDR_2003_chp_6_web.pdf
www.afrepren.org/Pubs/WorkingPapers/pdfs/wpp305.pdf
www.csir.co.za/websource/ptl0002/docs/boutek/akani/2001/nov/cpted.pdf
www.earthinstitute.columbia.edu/cubes/events/DarCS.htm
www.eco-logica.co.uk/WTPPabstracts07.html
www.itdp.org/STe/ste11/
www.lboro.ac.uk/gawc/rb/rb78.html
www.makingcitieswork.org/urbanThemes/city_governance/Slum_Upgrading
www.up.ac.za/academic/civil/divisions/transportation/SVC411/svc411_01planning.pdf
www.vtpi.org/tdm/tdm75.htm

African cities, planning bicycling

www.eco-logica.co.uk/WTPPabstracts07.html
www.ibike.org/bibliography/bike-policy.htm
www.ibike.org/publications.htm
www.mobility.de/brm/afri/kipke/af_kip6.htm
www.mobility.de/brm/plan/replogle/tp_rep4.htm
www.velomondial.net/velomondial2000/Html/PROCEED/TINDEX.HTM
www.web.net/~detour/links.html
www.worldbank.org/afr/ssatp/ut.htm

International Agencies

Clean Air Initiative, Non-Motorized Transport

www.cleanairnet.org/caiasia/1412/propertyvalue-17504.html

Clean Air Initiative, Role of Non-motorized Transport

www.cleanairnet.org/baq2003/1496/article-57787.html

Club of Amsterdam

www.clubofamsterdam.com/contentpress/Club%20of%20Amsterdam%20Newsletter%20Issue%2006.htm

Eco-Logica, UK

www.eco-logica.co.uk/OECD, Non-Motorized Transport

<http://info.uibk.ac.at/info/oecd-macroth/en/3717.html>

Institute for Transportation & Development Policy

www.itdp.org/programs/NMT.html

International Bicycle Fund, Africa, Bike & Non-Motorized Transport

www.ibike.org/africa.htm

United Nations Economic and Social Commission for Asia and the Pacific
[http:// www.unescap.org /tctd/gt/urban.htm](http://www.unescap.org/tctd/gt/urban.htm)

United Nations, Division for Sustainable Development
www.un.org/esa/sustdev/sdissues/transport/transp.htm

Velo Mondial, Author Index and PDF Downloads of papers
<http://www.velomondial.net/velomondial2000/Html/PROCEED/AINDEX.HTM>

Victoria Transport Policy Institute, Non-Motorized Transport Planning
www.vtpi.org

Virtual references, Integration of Motorized and Non-Motorized Transport
www.virtualref.com/uncred/1008.htm

World Bank, Non-Motorized Transport
www.worldbank.org/transport/urbtrans/nonmotor.htm

World Transport Policy & Practice Homepage
www.eco-logica.co.uk/WTPPhome.html

UN-Habitat – The Sustainable Cities Programme
www.unchs.org/programmes/sustainablecities/

World conference on transport research

World Conference on Transport Research Society
www.ish-lyon.cnrs.fr/let/wctrs/wctr.htm

www.travelium.com/info/538/131/10TH-World-Conference-on-Transport-Research

Transportation Research Board

Transportation Research Board Annual Meeting
<http://www4.trb.org/trb/annual.nsf>

NTL Catalog: Transportation Research Board 2003 Annual Meeting
http://ntl.bts.gov/card_view.cfm?docid=12441

Ministries of Transport

Australia, Ministry of Transport, New South Wales
www.transport.nsw.gov.au/links.html

Canada, Ministry of Transport
www.tc.gc.ca/

Canada, Ontario Ministry of Transportation
www.mto.gov.on.ca/english/

Denmark, Ministry of Transport
<http://www.trm.dk/sw523.asp>

Finland, Ministry of Transport and Communication
www.mintc.fi/www/sivut/english/default.html

Germany, Federal Ministry of Transport, Germany
www.luftrecht-online.de/english/bmv.htm

France, Ministry of Transport
<http://www.equipement.gouv.fr/institutionnelStatic/anglais/index.htm>

Japan, Ministry of Land, Infrastructure and Transport
www.mlit.go.jp/english/

Netherlands, Ministry of Transport
<http://www.verkeerenwaterstaat.nl/?lc=uk>

New Zealand, Ministry of Transport
www.transport.govt.nz

New Zealand, Cycle Network and Route Planning Guide
<http://www.ltsa.govt.nz/roads/cycle-network/chapter9.html>

Norway, Ministry of Transport
<http://odin.dep.no/sd/engelsk/bn.html>

South Africa, Department of Transport
www.transport.gov.za

Sweden, Ministry of Transport and Communications
<http://naring.regeringen.se/>

UK, Department for Transport
<http://www.dft.gov.uk/>

US Department of Transportation
www.dot.gov

Directory Transportation, Government Agencies
http://dir.yahoo.com/Recreation/Travel/Transportation/Government_Agencies/

References for Bicycle Planning

American Association of State Highway and Transportation Officials (AASHTO) *Guide for the Development of Bicycle Facilities*, AASHTO, Washington, DC, 1991.

General Site: www.transportation.org

American Planning Association, *Bicycle Facility Planning*, Planning Advisory Service Report 459, Chicago, IL, 1995.

General Site: www.planning.org

Bicycle Federation of America, *ProBike ProWalk 98 Resource Book*, 1998.

General Site: www.bikefed.org

Burden, Dan, *Walkable and Bicycle Friendly Communities*, Florida Dept. of Transportation, 1996.

General Site: www.walkable.org

Burrington, Stephen H., "Restoring the Rule of Law and Respect for Communities in Transportation," *Environmental Law Journal*, New York University, Volume 5, Number 3, 1996.

General Site: www.nyu.edu/pages/elj

California Department of Transportation *Bikeway Planning and Design, California DOT Highway Design Manual* Fourth Edition Chapter 1000, July 1990.

General Site: www.dot.ca.gov/

City of Cambridge, *Toward a Sustainable Future: Cambridge Growth Policy Document*, 1993.

City of Cambridge Mayor's Bicycle Committee, *Initial Report to Mayor Alice K. Wolf and the Cambridge City Council*, October 1991.

Colorado Department of Transportation, *Draft Bikeway Design Guidelines*, 1994.

General Site: www.dot.state.co.us

Commonwealth of Massachusetts Executive Office of Transportation and Construction and Massachusetts Highway Department, *Massachusetts Statewide Bicycle Transportation Plan*, 1998.

General Site: www.state.ma.us/mhd

Note: The Massachusetts Statewide Bicycle Transportation Plan is no longer available online. For more information about the plan, please contact Josh Lehman (Bicycle and Pedestrian Coordinator with the Massachusetts Highway Department) at 617-973-7329 josh.lehman@state.ma.us.

Conservation Law Foundation, *Road Kill: How Solo Driving Runs Down the Economy*, May 1994.

General Site: www.clf.org

Conservation Law Foundation, *Take Back Your Streets: How to Protect Communities from Asphalt and Traffic*, May 1995.

General Site: www.clf.org

Conservation Law Foundation, *CityRoutes, CityRights: Building Livable Neighborhoods and Environmental Justice by Fixing Transportation*, June 1998.

General Site: www.clf.org

Environmental Working Group, Bicycle Federation of America and Surface Transportation Policy Project, *Share the Road: Let's Make America Bicycle Friendly*, May 1997.

- Environmental Working Group: www.ewg.org
- Bicycle Federation of America: www.bikefed.org
- Surface Transportation Policy Project: www.transact.org
- Document Online: <http://ewg.org/reports/bikes/bikerecs.html>

Federal Highway Administration, *Bicycle Lanes versus Wide Curb Lanes: Operational and Safety Findings, Draft Study*, May 1998.

General Site: www.fhwa.dot.gov

Federal Highway Administration, *Bicycle Safety-Related Research Synthesis*, April 1995.

General Site: www.fhwa.dot.gov

Federal Highway Administration, *Bicycling & Walking in the Nineties and Beyond: Applying Scandinavian Experience to America's Challenge*, November 1994.

General Site: www.fhwa.dot.gov

Federal Highway Administration, *The National Bicycling and Walking Study: Transportation Choices for a Changing America*, Final Report plus 24 Case Studies, 1994.

General Site: www.fhwa.dot.gov

Federal Highway Administration, *Selecting Roadway Design Treatments to Accommodate Bicycles*, FHWA Manual, 1993.

General Site: www.fhwa.dot.gov

Federal Highway Administration, *Study Tour Report for Pedestrian and Bicyclist Safety in England, Germany and the Netherlands*, October 1994.

General Site: www.fhwa.dot.gov

Federal Highway Administration, *Safety Effectiveness of Highway Design Features*, Volume VI: Pedestrians and Bicyclists, 1991.

General Site: www.fhwa.dot.gov

Florida Department of Transportation Safety Office, *Florida Bicycle Facilities Planning and Design Manual*, April, 1995.

General Site: www.dot.state.fl.us

Institute of Traffic Engineers, *Residential Street Design and Traffic Control*, Wolfgang Hamburger et al., 1989.

General Site: www.ite.org

Institute of Transportation Engineers, *The Traffic Safety ToolBox: A Primer on Traffic Safety*, Washington, DC, 1994.

General Site: www.ite.org (online ordering available)

Massachusetts Highway Department, *Building Better Bicycling: A Manual for Improving Community Bicycling Conditions*, MA Highway Department, February 1994.

General Site: www.magnet.state.ma.us/mhd/bikepath/bikep.htm

Minnesota Department of Transportation, *Plan B: The Comprehensive State Bicycle Plan*, Minnesota DOT, 1990.

General Site: www.dot.state.mn.us/sti/biking.html

National Highway Institute, US Department of Transportation, Federal Highway Administration and National Highway Traffic Safety Administration, *Pedestrian and Bicyclist Safety and Accommodation*, Publication No. FHWA HI-96-028, May 1996.

- National Highway Institute: www.nhi.fhwa.dot.gov
- US Department of Transportation: www.dot.gov
- Federal Highway Administration: www.fhwa.dot.gov
- National Highway Traffic Safety Administration: www.nhtsa.dot.gov

North Carolina Department of Transportation, *North Carolina Bicycle Facilities Planning and Design Guidelines*, January 1994.

General Site: www.dot.state.nc.us/transit/bicycle

Northwestern University Traffic Institute, *Street Rating and Evaluation Methodology*, 1993.

General Site: <http://nuinfo.nwu.edu/traffic/index.html>

Oregon Department of Transportation, *Oregon Bicycle and Pedestrian Plan*, 1995.

- General Site: <http://www.odot.state.or.us/techserv/bikewalk/index.htm>
- Document Online: www.odot.state.or.us/techserv/bikewalk/obpplan.htm

Sorton, Alex and Thomas Walsh, "Urban and Suburban Bicycle Compatibility Street Evaluation Using Bicycle Stress Level," Transportation Research Board, Washington, DC, January 1994.

General Site: www.nas.edu/trb

United States Department of Transportation, "Implementing Effective Travel Demand Management Measures: Inventory of Measures and Synthesis of Experience," September 1993.

General Site: www.dot.gov

United States Department of Transportation, Federal Highway Administration, *Manual on Uniform Traffic Control Devices*, 1988.

- General Site: www.fhwa.dot.gov
- Document Online (partial): <http://mutcd.fhwa.dot.gov>

United States Department of Transportation, Federal Highway Administration, *National Personal Transportation Survey*.

- General Site: www.fhwa.dot.gov
- 1990 NPTS: www-cta.ornl.gov/npts/1990/index.html
- 1995 NPTS: www-cta.ornl.gov/npts/1995/Doc/index.shtml

United States. Department of Transportation, Federal Highway Administration, *Draft Report: Bicycle Lanes Versus Wide Curb Lanes: Operational and Safety Findings*, May 1998.

General Site: www.fhwa.dot.gov

United States Department of Transportation and Rails to Trails Conservancy, *Improving Conditions for Bicycling and Walking: A Best Practices Report*, January 1998.

- US Department of Transportation: www.fhwa.dot.gov
- Rails to Trails Conservancy: www.railtrails.org